

# PandarXT-16

16-Channel Medium-Range  
Mechanical Lidar  
User Manual



# Contents

- About This Manual..... 1**
- Safety Notice..... 2**
- 1 Introduction..... 9**
  - 1.1 Operating Principle ..... 9
  - 1.2 Lidar Structure ..... 10
  - 1.3 Channel Distribution..... 12
  - 1.4 Specifications ..... 14
- 2 Setup..... 18**
  - 2.1 Mechanical Installation..... 18
  - 2.2 Interfaces ..... 24
  - 2.3 Connection Box (Optional) ..... 28
  - 2.4 Get Ready to Use ..... 35
- 3 Data Structure..... 36**
  - 3.1 Point Cloud Data Packet ..... 37
  - 3.2 GPS Data Packet ..... 44
- 4 Web Control..... 50**
  - 4.1 Home..... 51
  - 4.2 Settings ..... 53
  - 4.3 Azimuth FOV ..... 61
  - 4.4 Operation Statistics ..... 64
  - 4.5 Upgrade ..... 65
- 5 Communication Protocol ..... 66**
- 6 Sensor Maintenance ..... 67**
- 7 Troubleshooting ..... 69**
- Appendix I Channel Distribution Data ..... 73**
- Appendix II Absolute Time of Point Cloud Data..... 74**
- Appendix III Power Supply Requirements ..... 80**
- Appendix IV Nonlinear Reflectivity Mapping ..... 82**
- Appendix V Legal Notice ..... 87**

# About This Manual

Please make sure to read through this user manual before your first use and follow the instructions herein when you operate the product. Failure to comply with the instructions may result in product damage, property loss, personal injuries, and/or a breach of warranty.

## ■ Access to This Manual

To obtain the latest version:

- Visit the Download page of Hesai's official website: <https://www.hesaitech.com/downloads/>
- Or contact your sales representative at Hesai
- Or contact Hesai's technical support team: [service@hesaitech.com](mailto:service@hesaitech.com)

## ■ Technical Support

If your question is not addressed in this user manual, please contact us at:

[service@hesaitech.com](mailto:service@hesaitech.com)

<https://www.hesaitech.com/technical-support/>

<https://github.com/HesaiTechnology>

(Please leave your questions under the corresponding GitHub projects.)

## ■ Legends

 Warnings: instructions that must be followed to ensure safe and proper use of the product.

 Notes: additional information that may be helpful.

# Safety Notice

- Please check the certification information on the product's nameplate and read through the corresponding certification warnings. If specific users require not to present certification information on the nameplate, please follow the agreed-to arrangements.
- If you incorporate this lidar product into your product(s), you are required to provide this user manual (or the means to access this user manual) to the intended users of your product(s).
- This lidar product is intended as a component of an end product. It is the responsibility of the end-product supplier to assess the risk of use in accordance with applicable standards, and inform the intended user of safety-related information.
- Should there be other agreements with specific users, the other agreements shall apply.
- Before using a product, please confirm with Hesai the development maturity of the product in a timely manner. For products still in development, Hesai makes no warranty of non-infringement nor assumes any responsibility for quality assurance.

## ■ Special Warnings

### Laser Safety

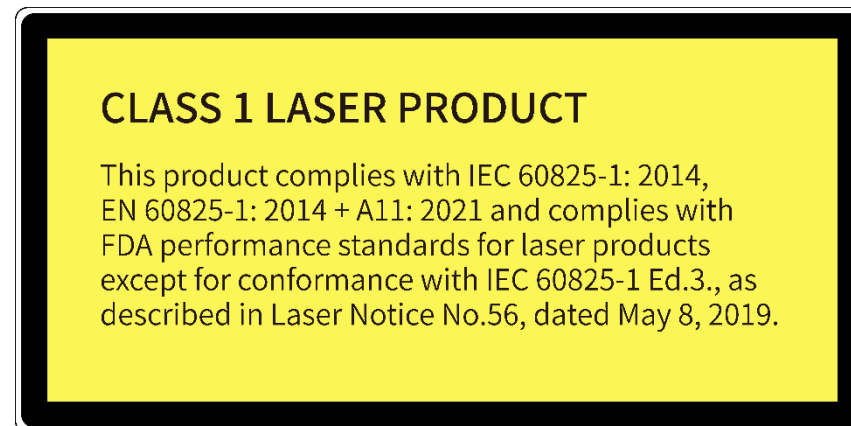

## Hot Surface



### Hot parts!

Burned fingers when handling the parts.

Wait one-half hour after switching off before handling parts.

## Abnormalities

In any of the circumstances listed below, stop using the product immediately:

- You suspect that the product malfunctions or is damaged. For example, the product produces significant noise or is visibly vibrating.
- You or other people in the nearby environment feel discomfort.
- Any device or equipment in the nearby environment malfunctions.

Meanwhile, contact Hesai Technology or an authorized Hesai Technology service provider for more information on product disposal.

## Prohibition of Disassembly

Unless expressly agreed to in writing by Hesai Technology, do NOT disassemble the product.

## ■ Operating Environment

### Radio Frequency Interference

- Please check the certification information on the product's nameplate and read through the corresponding certification warnings. If specific users require not to present certification information on the nameplate, please follow the agreed-to arrangements.
- Although the product is designed, tested, and manufactured to comply with the regulations on RF radiation (such as FCC, CE-EMC, or KCC), the radiation from the product may still influence electronic devices.

### **Vibration**

- If significant mechanical shocks and vibration may exist in the product's operating environment, please contact Hesai's technical support team to obtain the shock and vibration limits of this product model. Exposure to over-the-limit shocks or vibration may damage the product.
- Make sure to package the product in shock-proof materials to avoid damage during transport.

### **Explosive Atmosphere and Other Air Conditions**

- Do NOT use the product in any area where potentially explosive atmospheres are present, such as high concentrations of flammable chemicals, vapors, or particulates (including particles, dust, and metal powder) in the air.
- Do NOT expose the product to high concentrations of industrial chemicals, including liquefied gases that are easily vaporized (such as helium). Such exposure can damage or weaken the product's function.

### **Ingress Protection**

Please check the product's user manual for its IP rating (refer to the *Specifications* section). Make sure to avoid any ingress beyond that rating.

### **Operating Temperature**

Please check the product's user manual for its operating temperature (refer to the *Specifications* section). Make sure not to exceed the operating temperature range.

### **Recommended Storage Conditions**

Store the product in a dry, well-ventilated place. The recommended ambient temperature is  $23 \pm 5^{\circ}\text{C}$ , and the humidity between 30% and 70%.

### **Light Interference**

Certain precision optical instruments may be interfered by the laser light emitted from the product. Please check all the instructions of these instruments and take preventive measures if necessary. For example, certain product models are equipped with protective covers, which can be used to block laser light emission when the product is temporarily not used for measurement.

## ■ Personnel

### Recommended Operator Qualifications

The product should be operated by professionals with engineering backgrounds or experience in operating optical, electrical, and mechanical instruments. Please follow the instructions in this manual when operating the product and contact Hesai technical support if needed.

### Medical Device Interference

- Some components in the product can emit electromagnetic fields. If the product operators or other people in the nearby environment wear medical devices (such as cochlear implants, heart pacemakers, and defibrillators), make sure to consult the physicians and medical device manufacturers for medical advice, such as determining whether it is safe to work near the product.
- If you suspect that the product is interfering with your medical device, stop using the product immediately.

## ■ Installation and Operation

### Power Supply

- You are recommended to use only the cables and power adapters provided by Hesai Technology.
- If you are to design, configure, or select the power supply system (including cables) for the product, make sure to comply with the electrical specifications in the product's user manual (refer to the *Specifications* section and the *Power Supply Requirements* section); for technical support, please contact Hesai Technology. Do NOT use off-spec or damaged cables or adapters.

### Electrical Interface

- Before powering on the product, make sure the electrical interfaces are dry and clean. Do NOT power on the product in a humid environment.
- Please check the *Interfaces* section in the product's user manual and strictly follow the instructions on plugging/unplugging the connector. If abnormalities already exist (such as bent pins, broken cables, and loose screws), stop using the product and contact Hesai technical support.
- To prevent breakdown, turn off the power source before connection and disconnection.

## Eye Safety

The product is a Class 1 laser product. It satisfies the requirements of:

- IEC/EN 60825-1:2014
- EN 60825-1:2014+A11:2021
- 21 CFR 1040.10 and 1040.11 except for deviations (IEC 60825-1 Ed.3) pursuant to Laser Notice No.56, dated May 8, 2019.

Please follow the standard laser safety guidelines accordingly.

**CAUTION:** use of controls or adjustments or performance of procedures other than those specified herein may result in hazardous radiation exposure.

For maximum self-protection, it is strongly warned NOT to look into the transmitting laser through a magnifying product (microscope, eye loupe, magnifying glass, etc.).

 This product does not have a power switch. It starts operating once connected to power. During operation, the entire cover lens / optical window can be regarded as the product's laser emitting window; looking at the cover lens / optical window can be regarded as looking into transmitting laser.

## Product Enclosure

- The product contains metal, glass, plastic, as well as sensitive electronic components. In case the product has been dropped and burnt, stop using it immediately and contact Hesai technical support.
- Do NOT squeeze or pierce the product. If the product enclosure is broken, stop using it immediately and contact Hesai technical support.
- Certain product models contain high-speed rotating parts. To avoid potential injuries, do NOT operate the product if the enclosure is loose.
- Before operating the product, make sure it is properly and securely mounted. The mounting should prevent the product from leaving its mounting position in case of external forces (such as collisions, high winds, and stone impacts).
- If the product enclosure consists of fins or grooves, please wear gloves when handling the product. Applying too much pressure with your bare hands may cause cuts, bruises or other injuries.



### **Product Enclosure: Cover lens / optical window**

- Do NOT apply protective film, wax or any other substance on the cover lens / optical window.
- To keep the product's cover lens / optical window from fingerprints and other stains, do NOT touch the cover lens / optical window with bare hands. If the cover lens / optical window is already stained, please refer to the cleaning method in the *Sensor Maintenance* section of the user manual.
- To prevent scratches, do NOT touch the product's cover lens / optical window with hard or sharp objects. If scratches already exist, stop using the product and contact Hesai technical support. Severe scratches may affect the quality of the product's point cloud data.
- Before installing any exterior part, please ensure that each exterior part and its movable area do not overlap the detection blind zone of lidar product. For questions on determining the detection blind zone, contact Hesai technical support.

### **Hot Surface**

During operation or a time period after operation, the product's enclosure can be hot.

- To prevent discomfort or even burns, do NOT touch the product's enclosure with your skin.
- To prevent fires, do NOT touch the product's enclosure with flammable materials.

Certain product models support active heating of the cover lens / optical window to reduce the impact of ice and frost. Users can turn off this function.

- While active heating is ON, please avoid direct skin contact with the cover lens / optical window.
- For the location of the cover lens, please refer to the Introduction section in the product's user manual.

### **Peripherals**

The product may be used along with accessories and devices, such as suction cup mounts, extension cables, power supplies, network devices, GPS/PTP devices, and cleaning equipment. Please refer to all relevant specifications in the product's user manual, or contact Hesai technical support. Using off-spec or unsuitable devices may result in product damage or even personal injuries.

### **Firmware and Software Upgrading**

Make sure to use only the upgrade files provided by Hesai Technology. Make sure to observe all the instructions provided for that upgrade file.

## **Custom Firmware and Software**

- Before using a custom version of firmware and software, please thoroughly understand the differences in functions and in performance between this custom version and the standard version.
- Make sure to strictly follow all the instructions and safety precautions provided for that custom version. If the product does not function as anticipated, stop using the product immediately and contact Hesai technical support.

## **Point Cloud Data Processing**

Certain product models support one or more point cloud data processing features, include but are not limited to: Noise Filtering, Interstitial Points Filtering, Retro Multi-Reflection Filtering, and Non-Linear Reflectivity Mapping.

These features are configurable and are intended only to assist the user in extracting information from the point cloud data. Users are in full control of whether to use any of these features. Moreover, users are responsible for analyzing the product's intended application scenarios and evaluating the risk of enabling one or more of these features in combination.

The supported features for this product model can be found on web control.

## **■ Repair and Maintenance**

For product repair or maintenance issues, please contact Hesai Technology or an authorized Hesai Technology service provider.

### **Repair**

Unless expressly agreed to in writing by Hesai Technology, do NOT by yourself or entrust any third party to disassemble, repair, modify, or retrofit the product. Such a breach:

- can result in product damage (including but not limited to water resistance failure), property loss, and/or personal injuries;
- shall constitute a breach of warranty.

# 1 Introduction

This manual describes the specifications, installation, and data output format of PandarXT-16.

## 1.1 Operating Principle

Distance Measurement: Time of Flight (ToF)

- 1) A laser diode emits a beam of ultrashort laser pulses onto the target object.
- 2) The laser pulses are reflected after hitting the target object. The returning beam is detected by an optical sensor.
- 3) Distance to the object can be accurately measured by calculating the time between laser emission and receipt.

$d = \frac{ct}{2}$	d: distance c: speed of light t: travel time of the laser beam
--------------------	--

Figure 1.1 Distance Measurement Using Time of Flight

# 1.2 Lidar Structure

Laser emitters and receivers are attached to a motor that rotates horizontally.

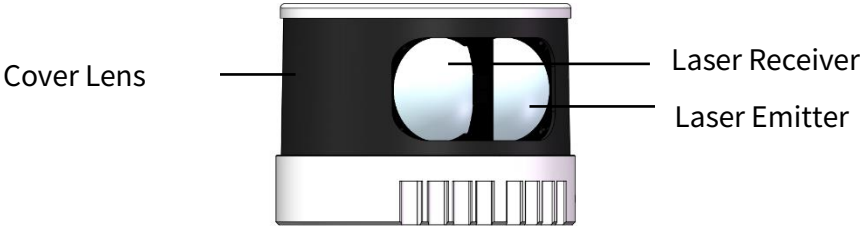

Figure 1.2 Partial Cross-Sectional Diagram

## ■ Side Connector

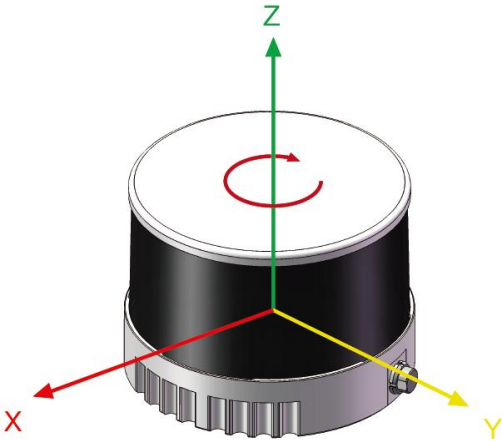

Figure 1.3 Coordinate System (Isometric View)

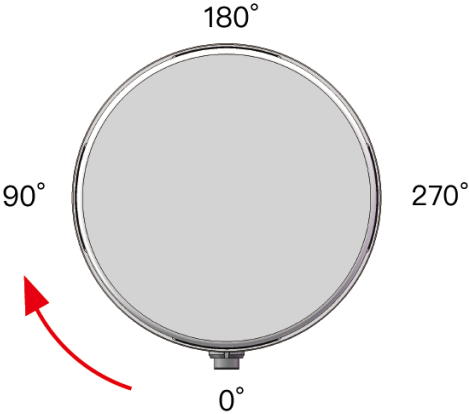

Figure 1.4 Rotation Direction (Top View)

## ■ Bottom Connector

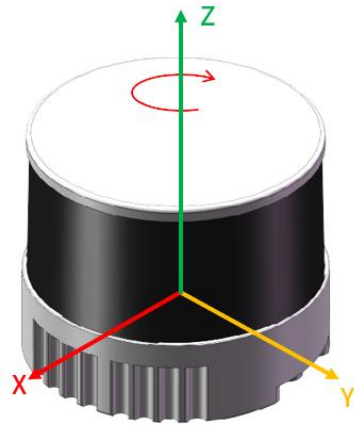

Figure 1.5 Coordinate System (Isometric View)

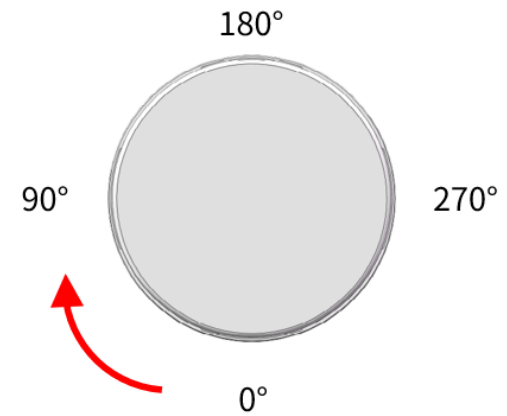

Figure 1.6 Rotation Direction (Top View)

The lidar's coordinate system is illustrated in Figure 1.3. Z-axis is the axis of rotation.

The origin is shown as a red dot in Figure 1.7 to Figure 1.10. All measurements are relative to the origin.

Lidar azimuthal position is defined in Figure 1.4. Y-axis corresponds to  $0^\circ$ .

For example, when all channels pass the  $90^\circ$  position:

the lidar is at the  $90^\circ$  position;

the Azimuth field in the corresponding data block in the Point Cloud Data Packet will be  $90^\circ$ .

### 1.3 Channel Distribution

The vertical resolution is 2° across the FOV, as shown in Figure 1.7.

■ Side Connector

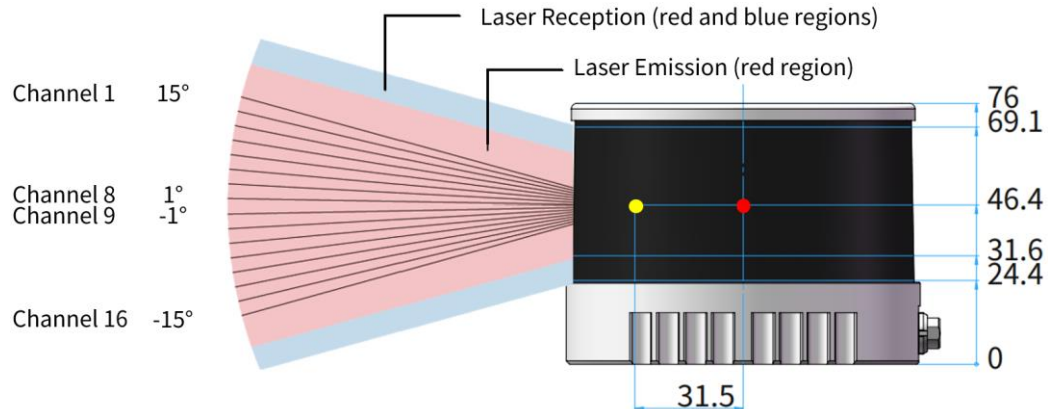

Figure 1.7 Channel Vertical Distribution

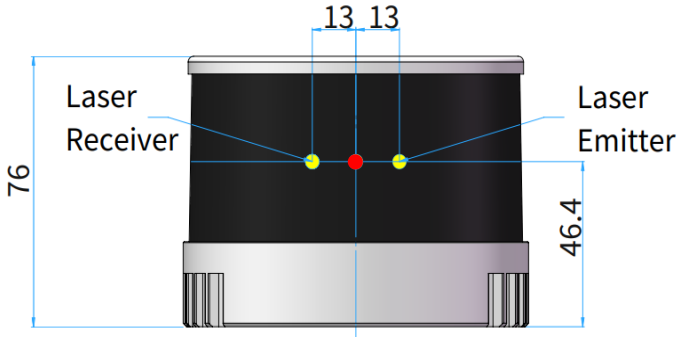

Figure 1.8 Laser Emitter/Receiver Position (Unit: mm)

## ■ Bottom Connector

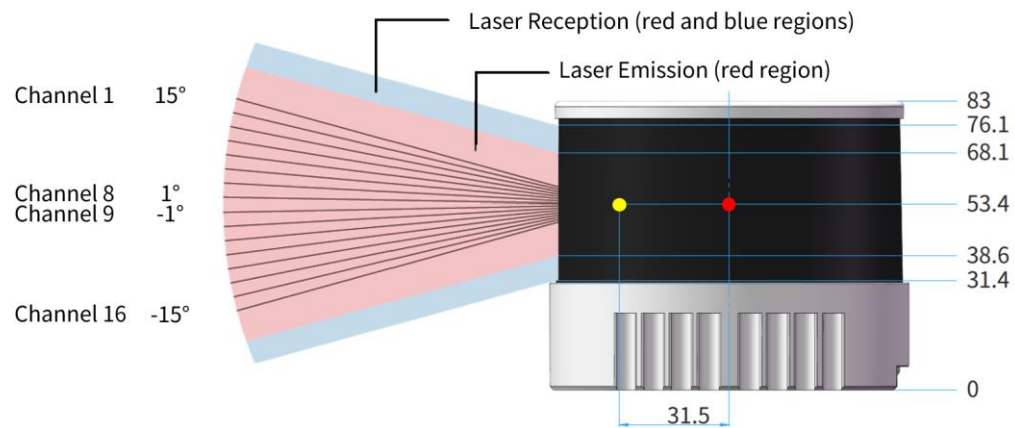

Figure 1.9 Channel Vertical Distribution

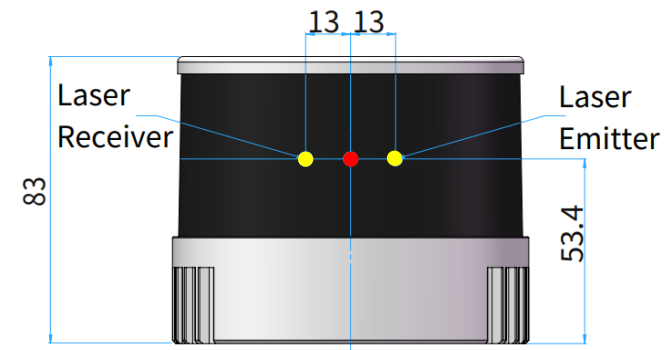

Figure 1.10 Laser Emitter/Receiver Position (Unit: mm)

Each channel has an intrinsic vertical angle offset.

The offsetted angles  $s$  are recorded in this lidar unit's angle correction file, which is provided when shipping the unit.

In case you need to obtain the file again:

- send PTC command 0x05, as described in Hesai TCP API Protocol (Section 5);
- or export the file using PandarView 2 (see the PandarView 2 user manual).

## 1.4 Specifications

SENSOR	
Scanning Method	Mechanical Rotation
Channel	16
Instrument Range	0.05 to 120 m
Range Capability ①	80 m @10% reflectivity (Channels 5 to 12) 50 m @10% (Channels 1 to 4, 13 to 16)
Range Accuracy ②	±1 cm (typical) ±2 cm (standard)
Range Precision ②	0.5 cm (typical, 1σ) 2 cm (standard)
FOV (Horizontal)	360°
Resolution (Horizontal)	0.09° (5 Hz) 0.18° (10 Hz) 0.36° (20 Hz)
FOV (Vertical)	30° (-15° to +15°)
Resolution (Vertical)	2°
Frame Rate	5 Hz, 10 Hz, 20 Hz
Return Modes	Single Return (Last, Strongest, First) Dual Return

 Specifications are subject to change. Please refer to the latest version. (Continued on the next page)

MECHANICAL/ELECTRICAL/OPERATIONAL	
Wavelength	905 nm
Laser Class	Class 1 Eye Safe
Ingress Protection	IP6K7
Dimensions	Height: 76.0 mm (Side Connector) 83.0 mm (Bottom Connector) Top/Bottom: Φ100.0 / 103.0 mm
Rated Voltage Range	DC 9 to 36 V
Power Consumption ③	9 W
Operating Temperature	-20°C to 65°C
Storage Temperature	-40°C to 85°C
Weight	0.8 kg (Side Connector) 0.9 kg (Bottom Connector)
DATA I/O	
Data Transmission	Ethernet 100BASE-TX, Slave Mode
Measurements	Distance, Azimuth Angle, Intensity
Data Points Generated	Single Return: 320,000 points/sec Dual Return: 640,000 points/sec
Point Cloud Data Rate	Single Return: 12.20 Mbps Dual Return: 24.40 Mbps
Clock Source	GPS / PTP
PTP Clock Accuracy ④	≤1 μs
PTP Clock Drift ④⑤	≤1 μs/s



(Continued)

① Range capability: typical value

- Test conditions: 100 klux ambient illuminance, PoD (probability of detection) > 90%
- The range capability of each channel is listed in Appendix I (Channel Distribution Data).

② Range accuracy and precision

- May vary with range, temperature, and target reflectivity.
- Typical values: the average among Channels 5 to 12, measured outdoors within 0.5 to 70 m, under 30°C ambient temperature, and with a target reflectivity of 50%.
  - Standard values: the average among all channels, measured indoors at 3/7/15/25 m, under room temperature, and with target reflectivities between 5% and 65%.

③ Power Consumption: typical value

- Test conditions: room temperature, 12 V (lidar input voltage), 600 rpm (spin rate)
- Not including accessories such as the connection box.
- The external power supply should be able to provide at least 30 W.

④ PTP Clock Accuracy and Clock Drift: typical value

- Test conditions: room temperature

⑤ PTP Clock Drift

- Defined as the drift at a constant temperature after the lidar (slave clock) loses connection to the PTP master.

## ■ Range Accuracy

Definition: the average of the differences between multiple measurements and the target's true distance, measured by a single channel

Conditions: 30°C ambient temperature, outdoors; Channels 5 to 12

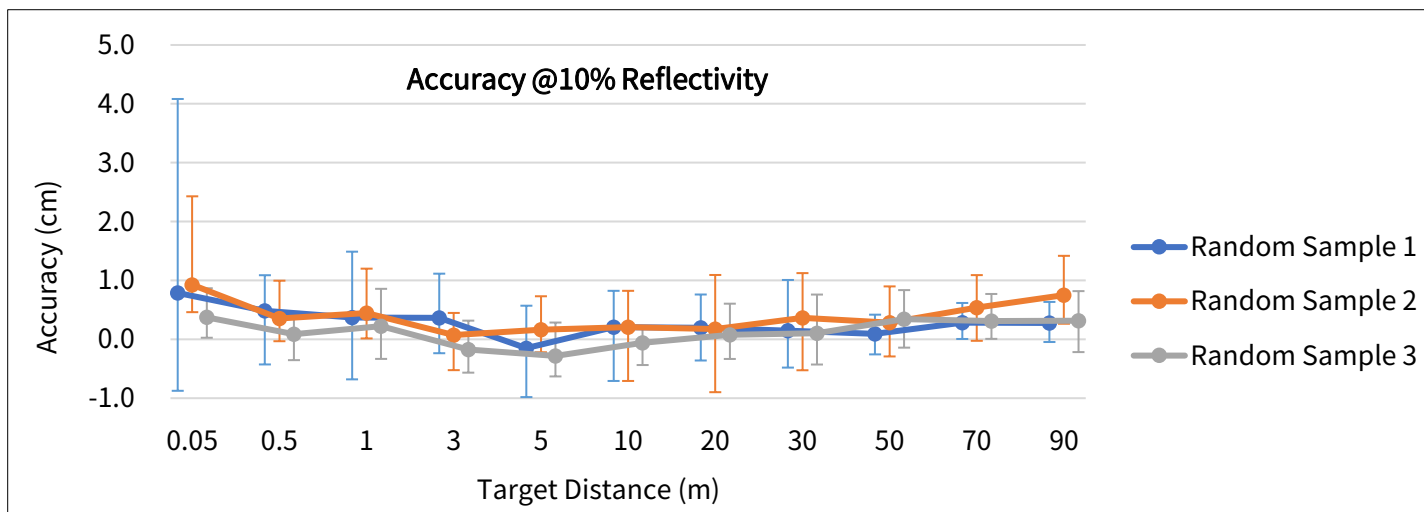
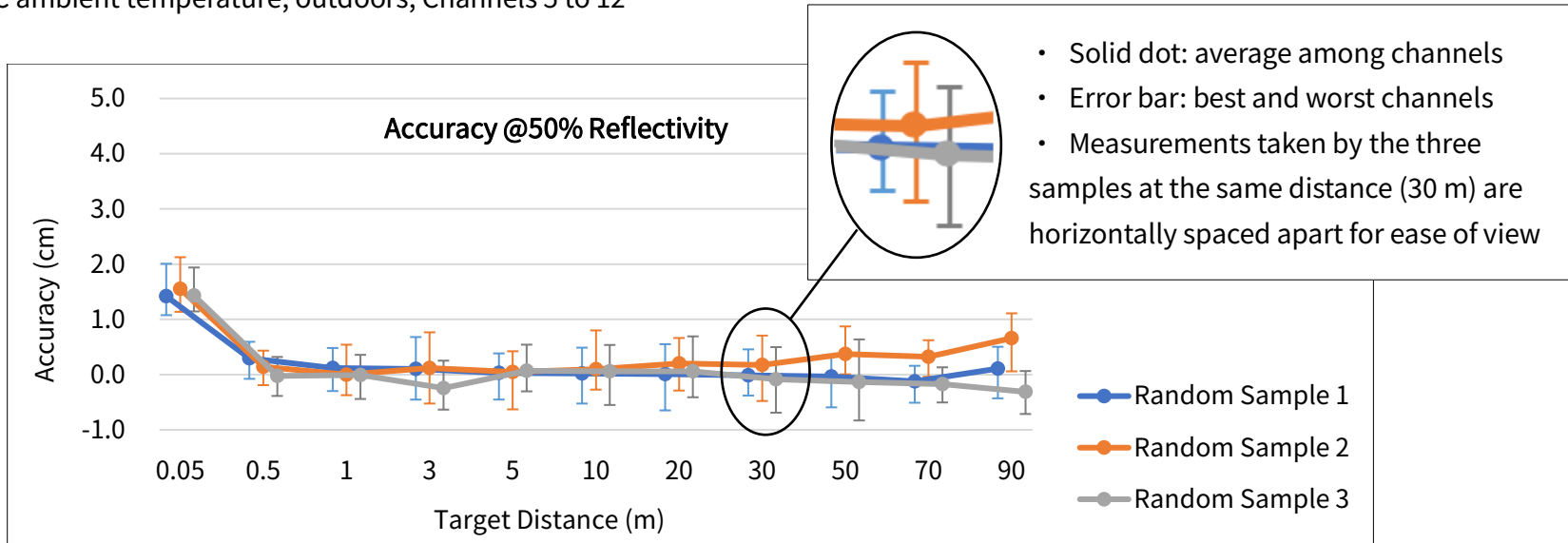

## ■ Range Precision

Definition: the standard deviation among multiple measurements, measured by a single channel

Conditions: 30°C ambient temperature, outdoors; Channels 5 to 12

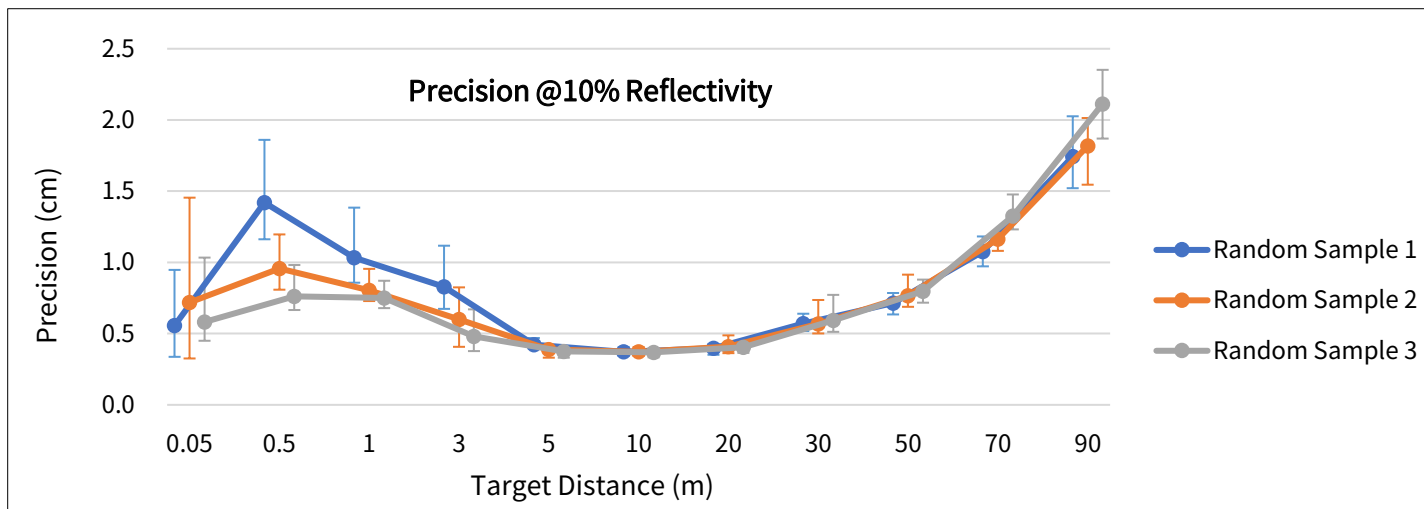
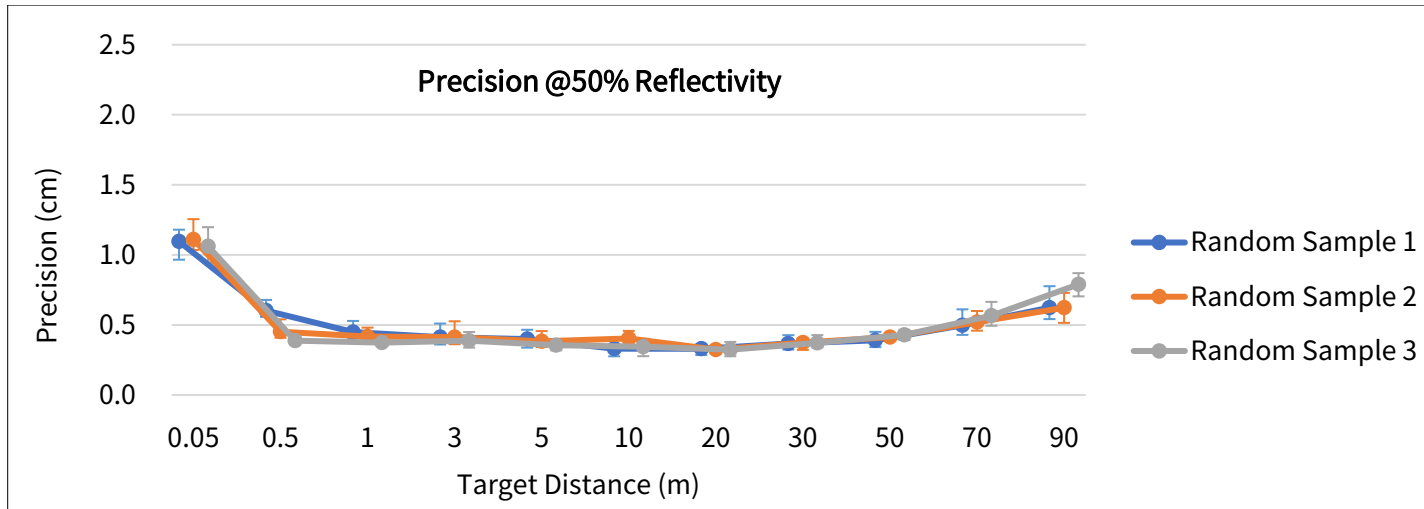

## 2 Setup

### 2.1 Mechanical Installation

#### 2.1.1 Side Connector

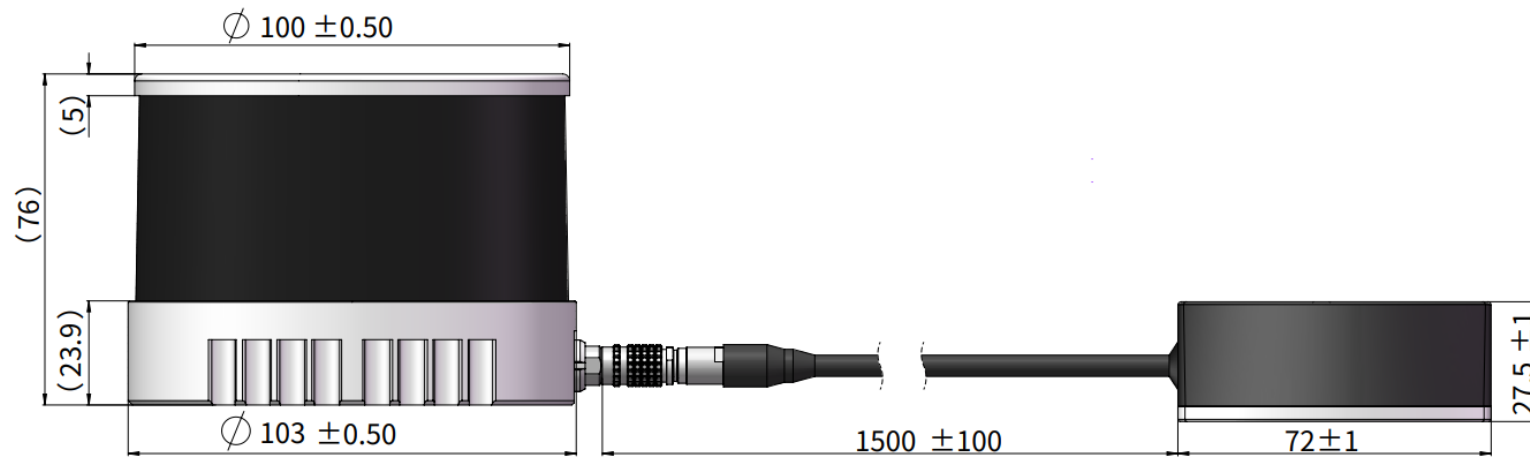

Figure 2.1 Front View (Unit: mm)

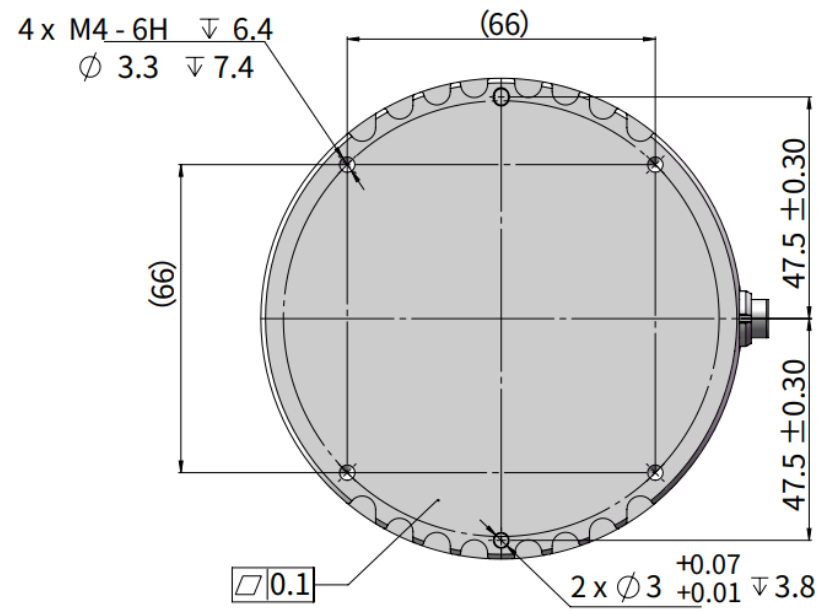

Figure 2.2 Bottom View (Unit: mm)

■ Recommended Installation

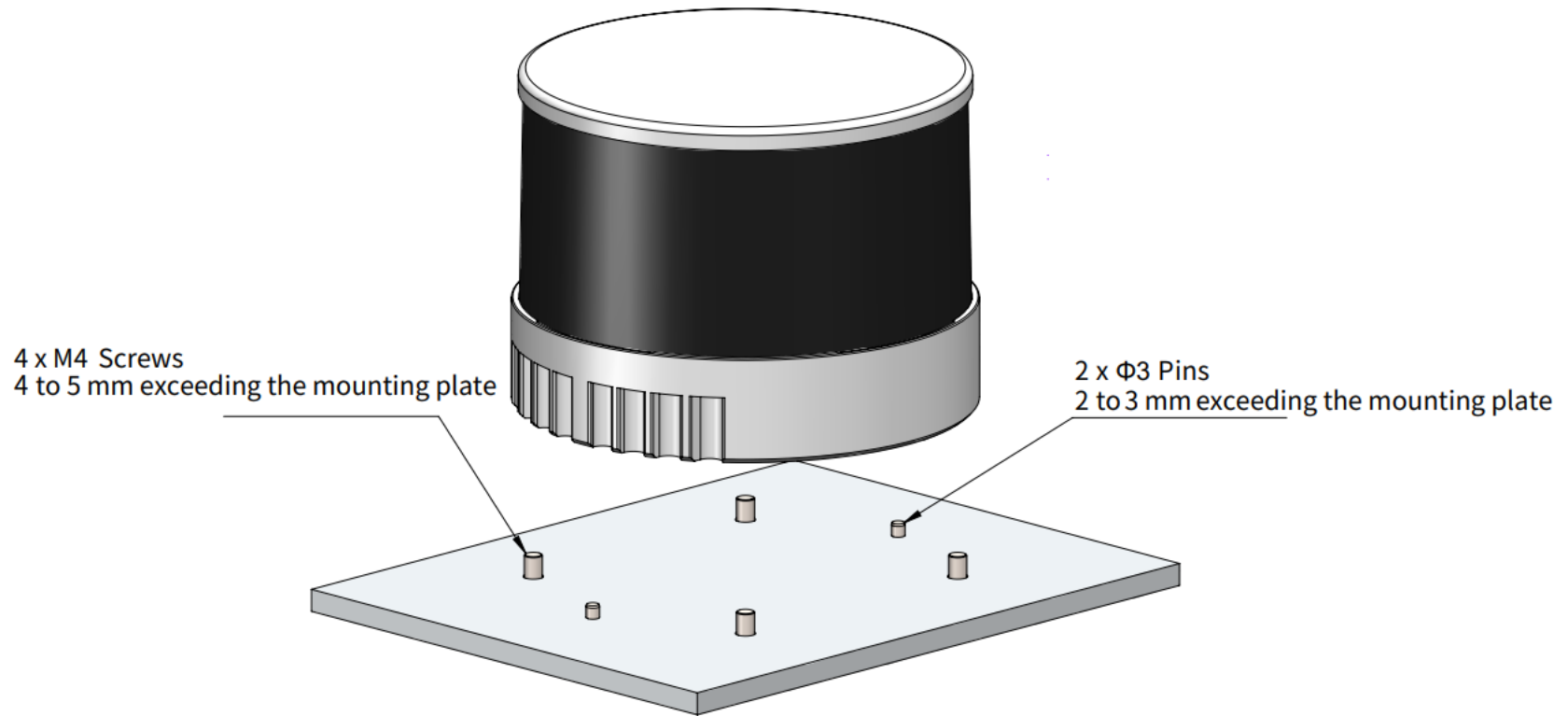

Figure 2.3 Recommended Installation

## 2.1.2 Bottom Connector

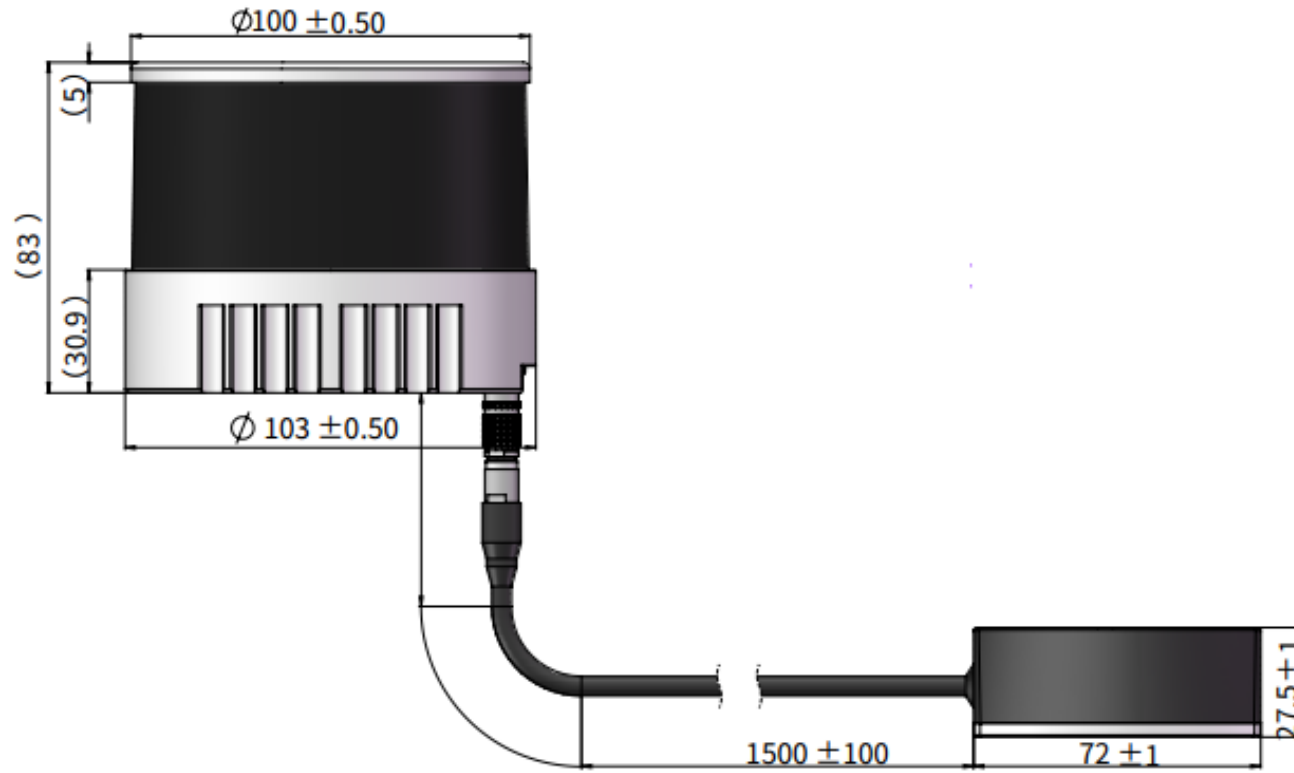

Figure 2.4 Front View (Unit: mm)

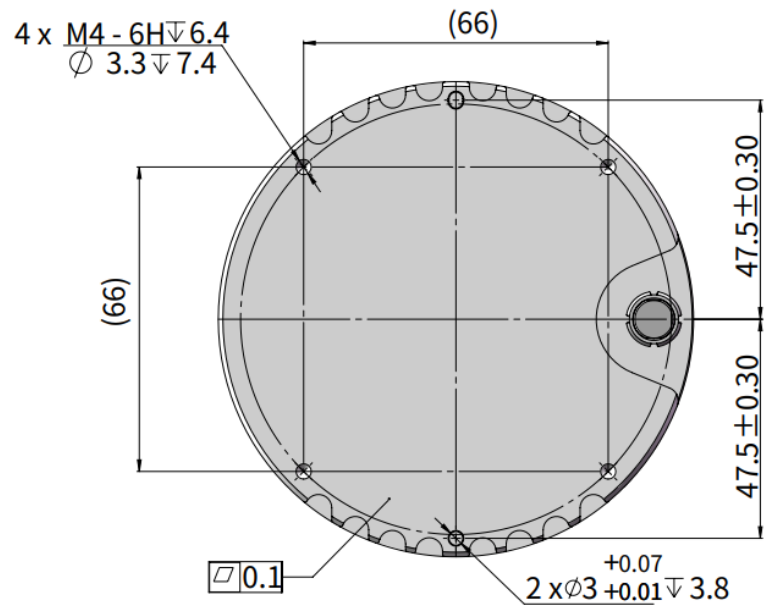

Figure 2.5 Bottom View (Unit: mm)



■ Recommended Installation

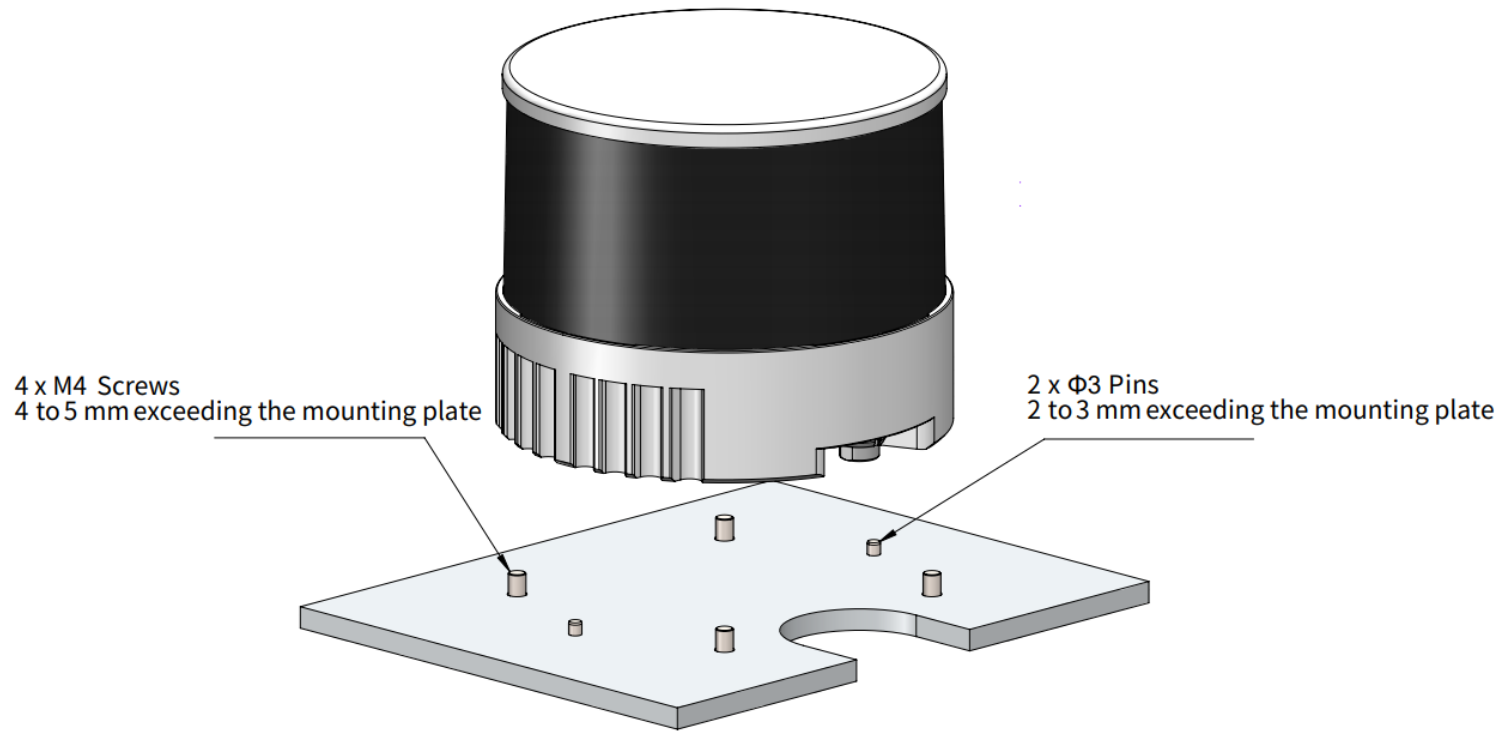

Figure 2.6 Recommended Installation

## 2.2 Interfaces

Lemo part number: EEG.0T.309.CLN (female socket, on the lidar)

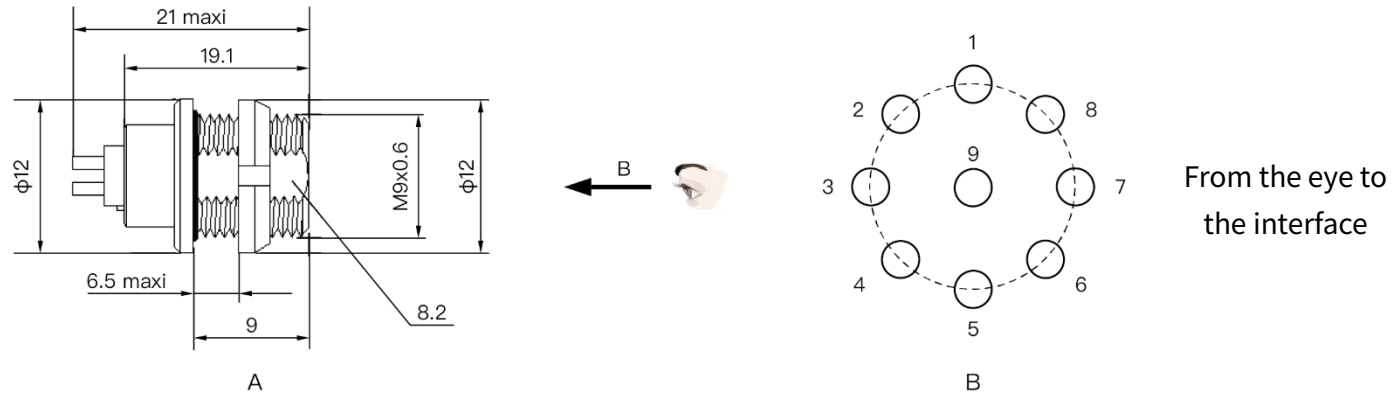

Figure 2.7 Lemo Connector (Female Socket)

## 2.2.1 Pin Description

Pin #	Signal	Wire Color	Voltage	Wire Gauge
1	GPS PPS	BLACK	3.3 to 12 V	28 AWG
2	GPS DATA	PURPLE	-13 to +13 V	28 AWG
3	GND	BROWN	0 V	26 AWG
4	VIN	WHITE	9 to 36 V	26 AWG
5	Ethernet TX+	YELLOW	-1 to 1 V	28 AWG

Pin #	Signal	Wire Color	Voltage	Wire Gauge
6	Ethernet TX-	GREEN	-1 to 1 V	28 AWG
7	Ethernet RX+	PINK	-1 to 1 V	28 AWG
8	Ethernet RX-	GRAY	-1 to 1 V	28 AWG
9	-	-	-	-

Notes: Red and Blue wires are unused

### Notes

- For the GPS PPS signal, pulse width is recommended to be over 1 ms, and the cycle is 1 s (rising edge to rising edge).
- The blue wire is not used. Pin 9 may be reserved in previous batches.

 Before connecting or disconnecting an external GPS signal (either using the cable's GPS wire or via the connection box's GPS port), make sure the lidar is powered off. If the lidar has to stay powered on, make sure to:

- ground yourself in advance
- avoid touching the GPS wire or GPS port with bare hands

💡 The timing requirements of GPS PPS and GPS Serial Data (NMEA) are shown below:

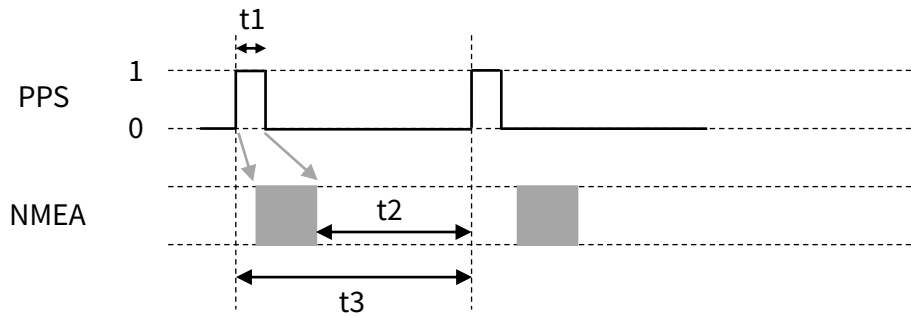

PPS cycle	$t_3 = 1 \text{ s} \pm 50 \mu\text{s}$ (rising edge to rising edge)
PPS pulse width	$t_1 \geq 1 \text{ ms}$ (10 to 100 ms recommended)
Timing relationship	NMEA signal starts after the PPS rising edge of the current second, and ends after the PPS falling edge of the current second, as shown by the gray arrows in figure above. NMEA signal ends before the PPS rising edge of the next second; $t_2 \geq 100 \text{ ms}$ .

## 2.2.2 Cables

OD (outside diameter) =  $5.0 \pm 0.2 \text{ mm}$

Minimum bend radius:  $10 * \text{OD}$

### 2.2.3 Connector Use

Connection	Disconnection
<ul style="list-style-type: none"> <li>• Turn off the power source.</li> <li>• Make sure the red dot on the cable's plug faces upward, so that the alignment key matches the slot on the lidar side.</li> <li>• Push the plug straight into the lidar's socket.</li> </ul>	<ul style="list-style-type: none"> <li>• Turn off the power source.</li> <li>• Hold the plug's shell and pull the plug straight from the socket.</li> </ul>

#### **⚠ Warnings**

- DO NOT attempt to force open a connection by pulling on the cables or by twisting the connectors in any way. Doing so can loosen the connectors' shells, or even damage the contacts.
- In case a connector's shell is accidentally pulled off, stop using the connector and contact Hesai technical support.
- DO NOT attempt to assemble the connector's shell and cable collet; DO NOT connect a connector without its shell. Doing so may damage the lidar's circuits.

Before connection: make sure the red dot faces upward

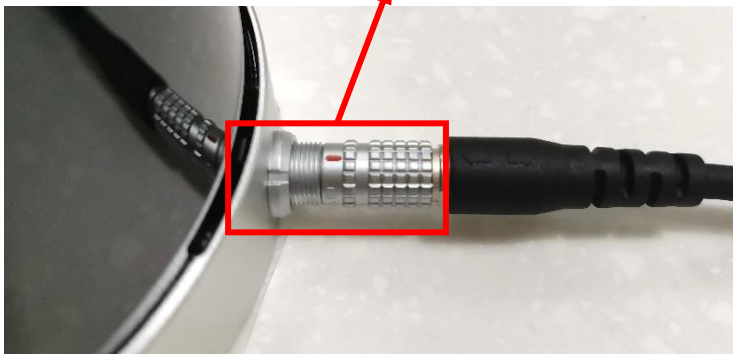

Slot on the lidar side



Alignment key on the cable side

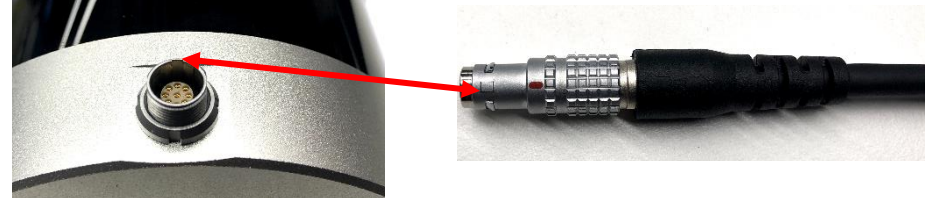

Figure 2.8 Lemo Connection

## 2.3 Connection Box (Optional)

Users may connect the lidar directly or using the connection box.

Lemo part number: FGG.0T.309.CLAC50Z (male plug, on the connection box)

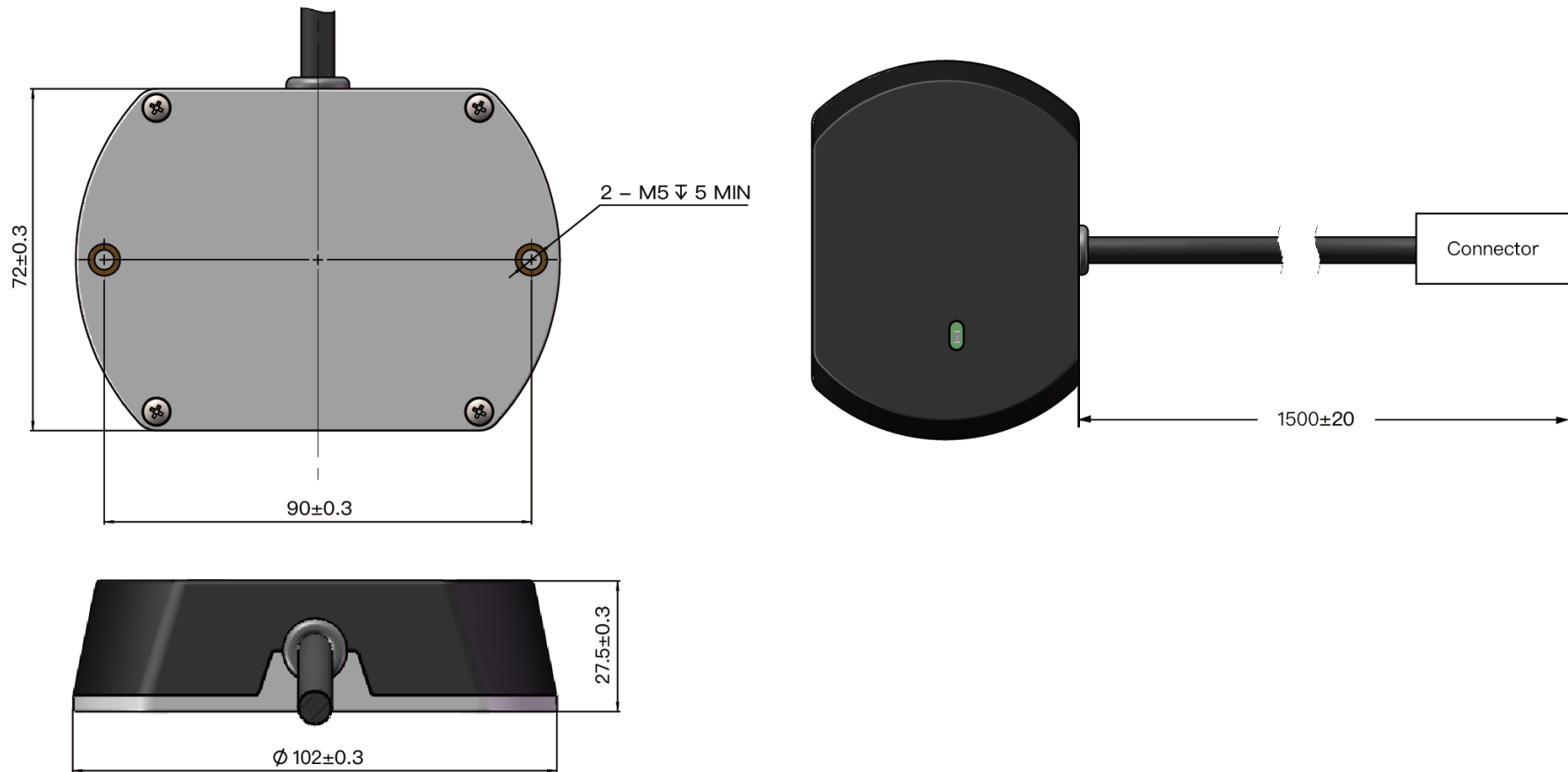

Figure 2.9 Connection Box (Unit: mm)

### 2.3.1 Connection Box Interfaces

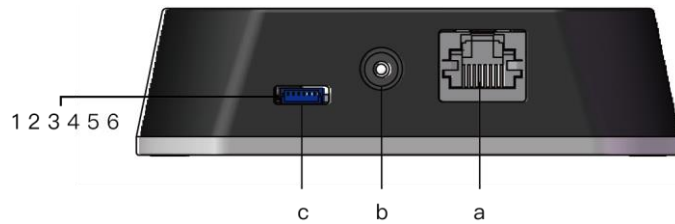

Figure 2.10 Connection Box (Front)

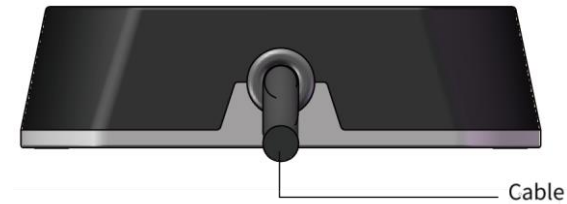

Figure 2.11 Connection Box (Back)

Port #	Port Name	Description
a	Standard Ethernet Port	RJ45, 100 Mbps Ethernet
b	Power Port	Connects to a DC power adapter
c	GPS Port	Connector part number: JST SM06B-SRSS-TB Recommended connector for the external GPS module: JST SHR-06V-S-B Voltage standard: RS232      Baud rate: 9600 bps

The GPS port pin numbers are 1 to 6 from left to right, defined as follows:

Pin #	Direction	Pin Description	Requirements
1	Input	PPS (pulse-per-second) signal for synchronization	3.3 V to 12 V      Rising edge $\leq 500$ ns Recommended pulse width $\geq 1$ ms Cycle: 1 s (from rising edge to rising edge)
2	Output	Power for the external GPS module	5 V
3	Output	Ground for the external GPS module	-
4	Input	Receiving serial data from the external GPS module	RS232 level
5	Output	Ground for the external GPS module	-
6	-	Reserved	-

### 2.3.2 Connection

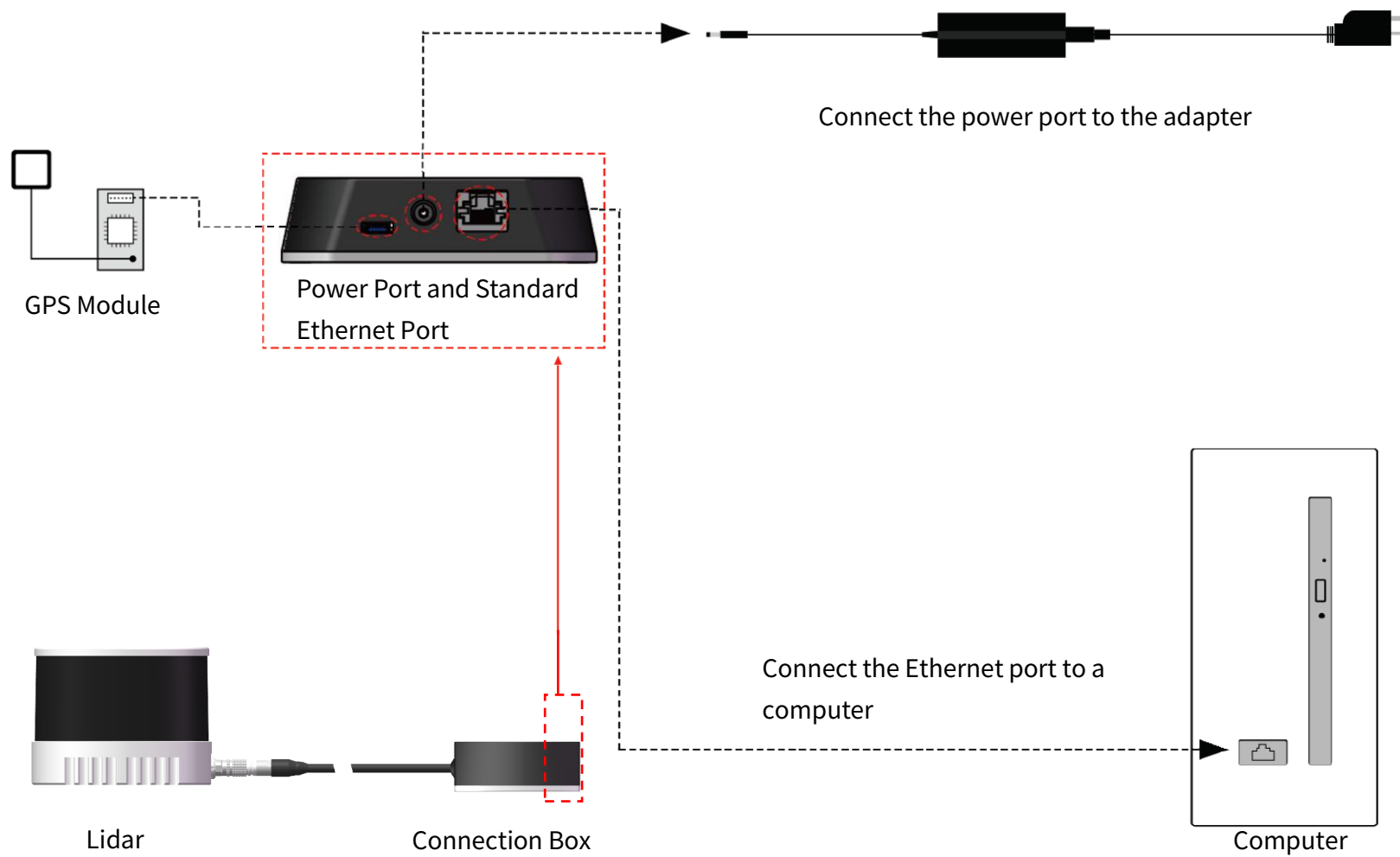

Figure 2.12 Connection Box - Side Connector (Connection with GPS)





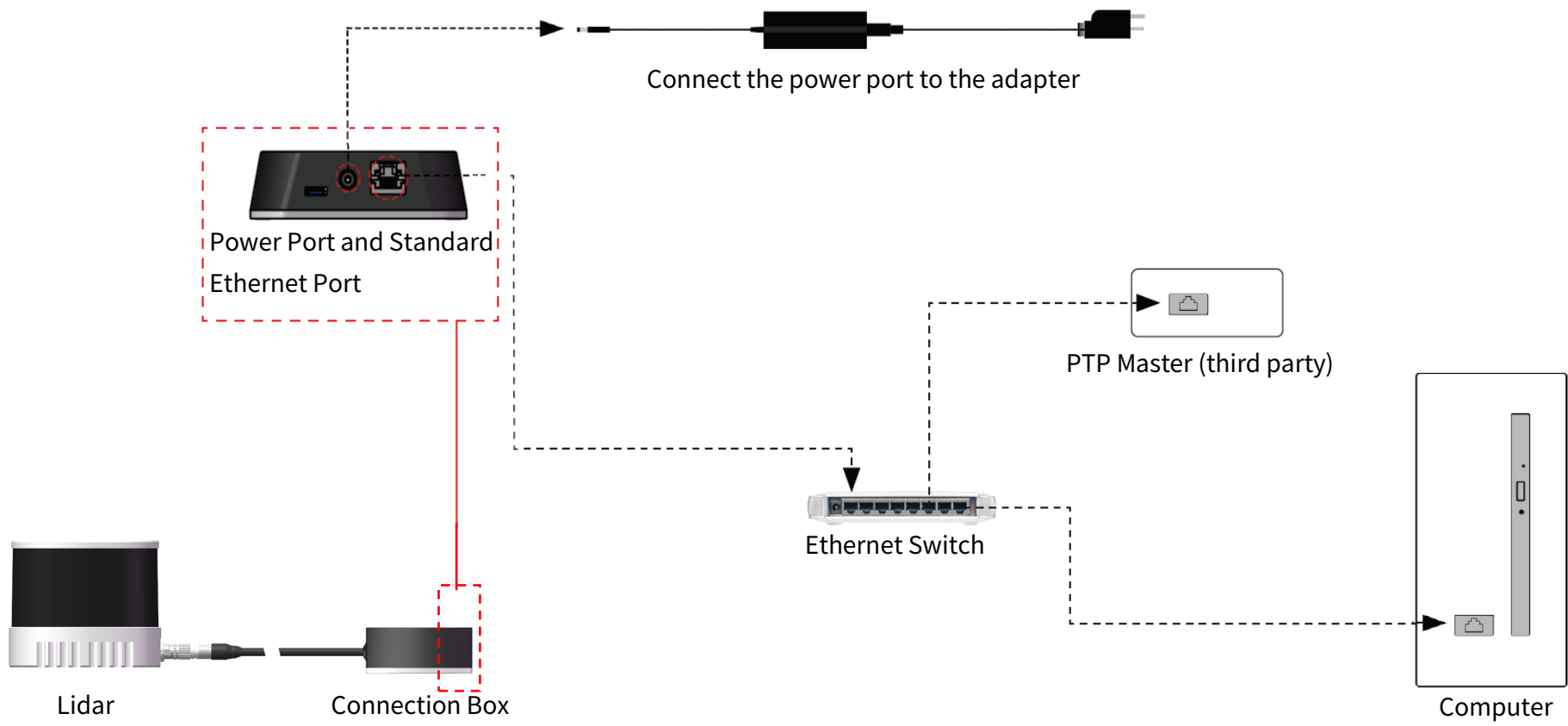

Figure 2.13 Connection Box - Side Connector (Connection with PTP)

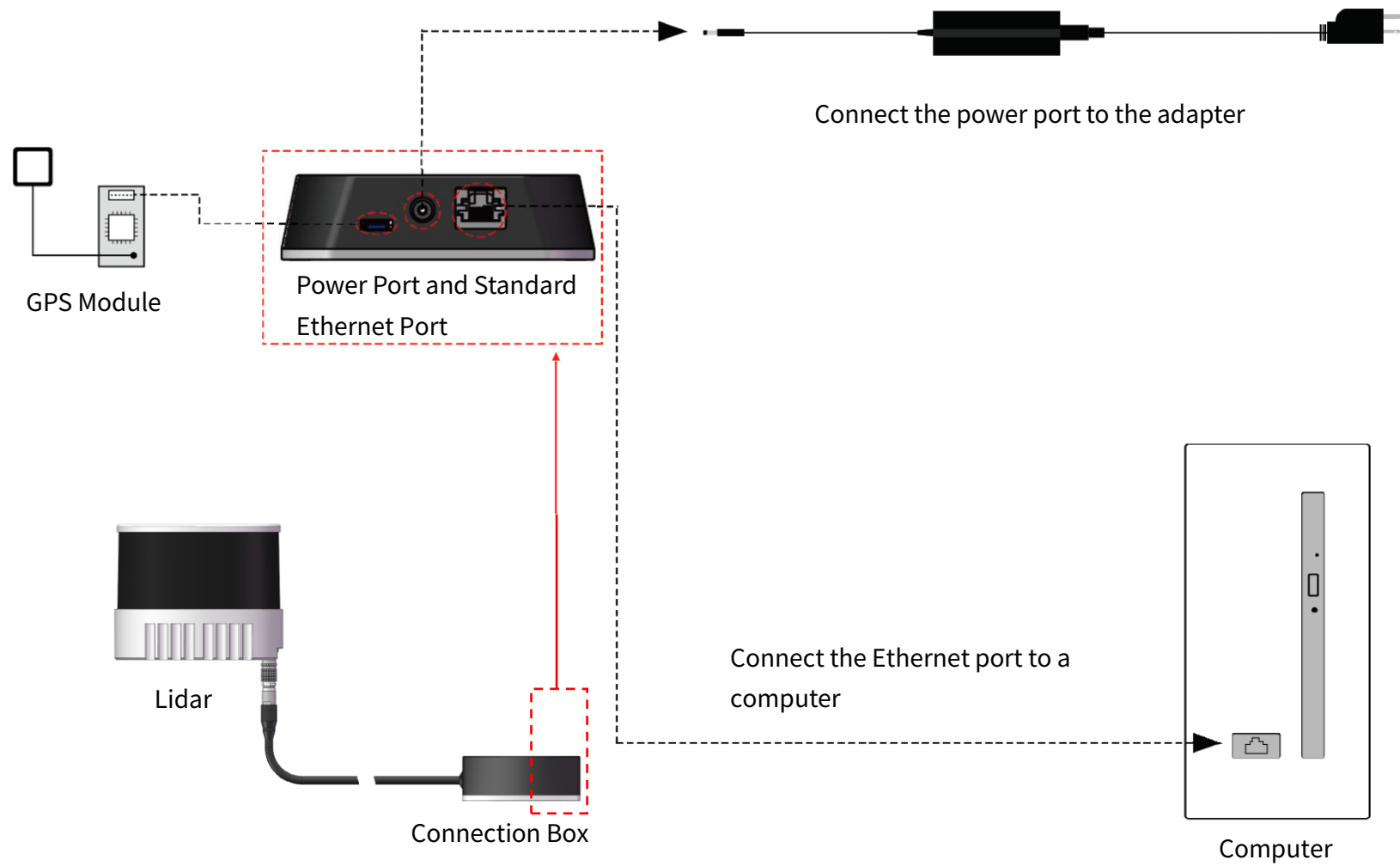

Figure 2.14 Connection Box - Bottom Connector (Connection with GPS)

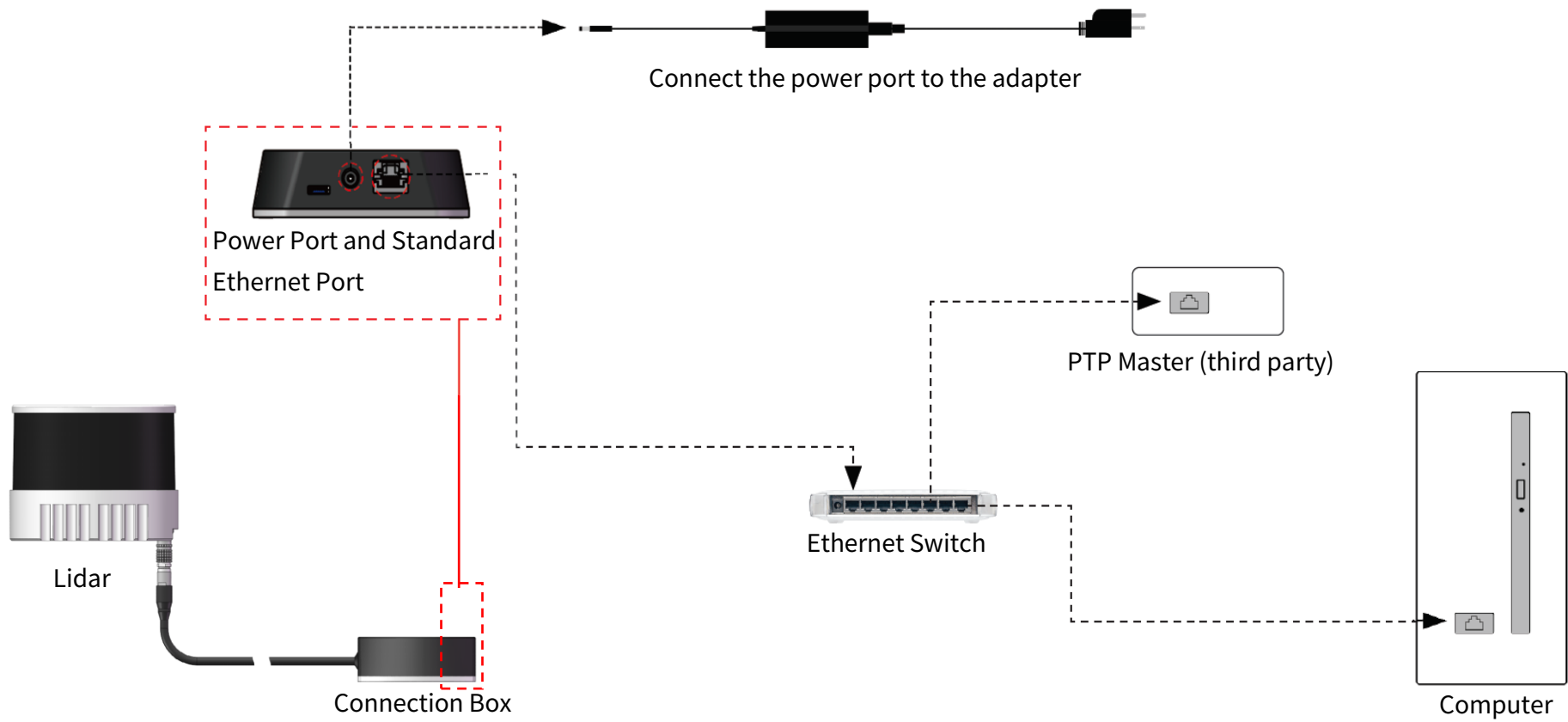

Figure 2.15 Connection Box - Bottom Connector (Connection with PTP)

s

## 2.4 Get Ready to Use

Before operating the lidar, strip away the protective cover outside the cover lens.

The lidar does not have a power switch. It starts operating once connected to power and the Ethernet.

To receive data on your PC, set the PC's IP address to 192.168.1.100 and subnet mask to 255.255.255.0

For Ubuntu:	For Windows:
Input this ifconfig command in the terminal: ~\$ sudo ifconfig enp0s20f0u2 192.168.1.100 (replace enp0s20f0u2 with the local Ethernet port name)	Open the Network Sharing Center, click on "Ethernet" In the "Ethernet Status" box, click on "Properties" Double-click on "Internet Protocol Version 4 (TCP/IPv4)" Configure the IP address to 192.168.1.100 and subnet mask to 255.255.255.0

To record and display point cloud data (see PandarView 2 User Manual).

To set parameters, check device info, or upgrade firmware/software (see Section 4 Web Control)

To obtain the SDKs (Software Development Kits) for your product model,

- please find the download link at: [www.hesai.tech/en/download](http://www.hesai.tech/en/download) (Product Documentation → select product model)
- or visit Hesai's official GitHub page: <https://github.com/HesaiTechnology>

# 3 Data Structure

The lidar outputs Point Cloud Data Packets and GPS Data Packets.

Each data packet consists of an Ethernet header and UDP data.

Unless otherwise specified, all the multi-byte fields are unsigned values in little endian format.

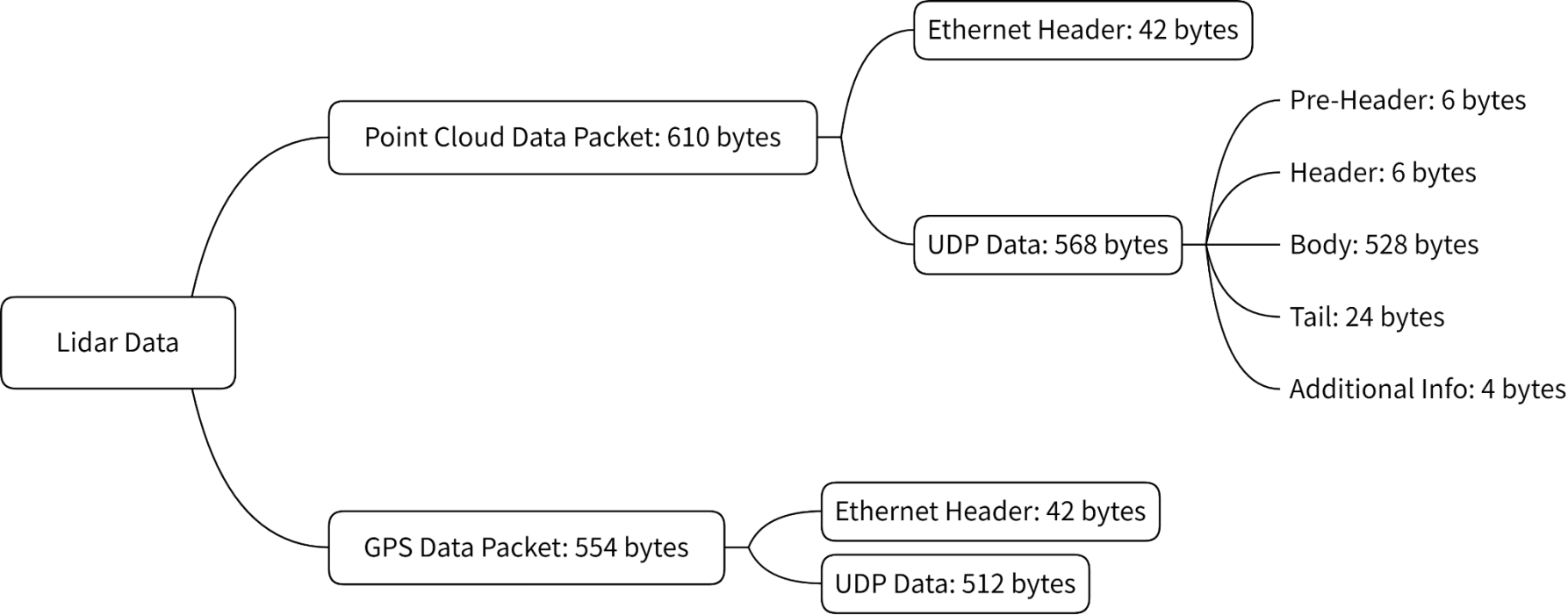

Figure 3.1 Data Structure

## 3.1 Point Cloud Data Packet

### 3.1.1 Ethernet Header

Each lidar has a unique MAC address. The source IP is 192.168.1.201 by default, and the destination IP is 255.255.255.255 (broadcast).

Point Cloud Ethernet Header: 42 bytes		
Field	Bytes	Description
Ethernet II MAC	12 bytes	Destination: broadcast (0xFF: 0xFF: 0xFF: 0xFF: 0xFF: 0xFF) Source: (xx:xx:xx:xx:xx:xx)
Ethernet Data Packet Type	2 bytes	0x08, 0x00
Internet Protocol	20 bytes	Shown in Figure 3.2
UDP Port Number	4 bytes	UDP source port (0x2710, representing 10000)      Destination port (0x0940, representing 2368)
UDP Length	2 bytes	0x0240, representing 576 bytes (8 bytes more than the size of the Point Cloud UDP Data, shown in Figure 3.1)
UDP Checksum	2 bytes	Shown in the figure below

```
▼ Internet Protocol Version 4, Src: 192.168.1.201, Dst: 255.255.255.255
  0100 .... = Version: 4
  .... 0101 = Header Length: 20 bytes (5)
  > Differentiated Services Field: 0x00 (DSCP: CS0, ECN: Not-ECT)
    Total Length: 1108
    Identification: 0x7f1d (32541)
  > Flags: 0x4000, Don't fragment
    Time to live: 64
    Protocol: UDP (17)
    Header checksum: 0xf50a [correct]
    [Header checksum status: Good]
    [Calculated Checksum: 0xf50a]
    Source: 192.168.1.201
    Destination: 255.255.255.255
```

Figure 3.2 Point Cloud Ethernet Header - Internet Protocol

### 3.1.2 UDP Data

#### ■ Pre-Header: 6 bytes

Field	Bytes	Description
0xEE	1	SOP (start of packet)
0xFF	1	SOP (start of packet)
Protocol Version Major	1	Main class of the point cloud UDP packet structure Currently 0x06
Protocol Version Minor	1	Subclass of the point cloud UDP packet structure Currently 0x01
Reserved	2	-

#### ■ Header: 6 bytes

Field	Bytes	Description
Laser Num	1	0x10 (16 channels)
Block Num	1	0x08 (8 blocks per packet)
First Block Return	1	Reserved
Dis Unit	1	0x04 (4 mm)
Return Number	1	0x02 (each channel can generate two returns maximum)
UDP Seq	1	[7:1] is reserved Least significant bit [0] shows whether this packet includes a UDP sequence number field 1 - UDP sequence ON



■ **Body: 528 bytes (8 blocks)**

Block 1	Block 2	Block 3	...	Block 8
Azimuth 1	Azimuth 2	Azimuth 3	...	Azimuth 8
Channel 1	Channel 1	Channel 1	...	Channel 1
Channel 2	Channel 2	Channel 2	...	Channel 2
...	...	...	...	...
Channel 16	Channel 16	Channel 16	...	Channel 16

Block size = size of Azimuth + 16 \* size of Channel X

Each Block in the Body: 66 bytes			
Field	Bytes	Description	
Azimuth	2	Current reference angle of the rotor Unit: 0.01°	
Channel X	4	2-byte Distance	Distance Value = Distance * Dis Unit  See the Dis Unit field in the Header.
		1-byte Reflectivity	Range: 0 to 255 The mapping from this field to target reflectivity can be selected in Section 4.2 (Web Control – Settings)
		Reserved	-

Three single-return modes and three dual-return modes are available (see the Return Mode field in the Tail of Point Cloud UDP Data).

In a dual-return mode,

- the measurements from each round of firing are stored in two adjacent blocks (see table below);
- the Azimuth of these two blocks are the same.

Return Mode field	Block 1	Block 2	Note
0x39	Last return	Strongest return	If the last return is also the strongest, then Block 2 stores the second strongest return.
0x3B	Last return	First return	If there is only one return, then Block 1 and Block 2 store the same data.
0x3C	First return	Strongest return	If the first return is also the strongest, then Block 2 stores the second strongest return.

■ Tail: 24 bytes

Field	Bytes	Description
Reserved	10	-
Return Mode	1	0x33 - First Return                      0x39 - Dual Return (Last, Strongest) 0x37 - Strongest Return                0x3B - Dual Return (Last, First) 0x38 - Last Return                        0x3C - Dual Return (First, Strongest)
Motor Speed	2	Unit: RPM

Field	Bytes	Description	
Date & Time	6	The absolute UTC time of this data packet, accurate to the second.	
		Each Byte	Range
		Year (current year minus 1900)	$\geq 70$
		Month	1 to 12
		Day	1 to 31
		Hour	0 to 23
		Minute	0 to 59
		Second	0 to 59
Timestamp	4	The " $\mu$ s time" part of the absolute time of this data packet (defined in Appendix II) Unit: $\mu$ s      Range: 0 to 1000000 $\mu$ s (1 s)	
Factory Information	1	0x42	

■ Additional Info: 4 bytes

Field	Bytes	Description
UDP Sequence	4	Sequence number of this UDP packet 0 to 0xFF FF FF FF

### 3.1.3 Point Cloud Data Analysis

Take Channel 5 in Block 2 as an example:

#### ■ Analyze the vertical angle of a data point

The designed vertical angle of Channel 5 is 7°, according to Appendix I (Channel Distribution)

#### 💡 Notes

- The accurate vertical angle is recorded in this LiDAR's unit's angle correction file, see Section 1.3 (Channel Distribution).
- 0° is the horizontal direction; define upward as positive (see Figure 1.5).
- Channel # counts from 1, top to bottom.

#### ■ Analyze the horizontal angle of a data point

💡 Y-axis is the 0° position; define clockwise in the top view as positive (see Figure 1.4).

Horizontal angle = ① + ② + ③

① Rotor reference angle during the current round of firing

In the Azimuth field of Block 2.

① Horizontal angle offset of the channel

The designed offset for Channel 5 is 0°, according to Appendix I (Channel Distribution Table).

💡 The accurate horizontal angle offset is recorded in this LiDAR's unit's angle correction file, see Section 1.3 (Channel Distribution).

③ Firing time angular offset of the channel = ④ \* ⑤

④ Firing time offset of the channel

Look up the table in Appendix II (Absolute Time of Point Cloud Data).

⑤ Spin rate of the motor

See Section 4.1 (Web Control – Home).

■ Analyze the distance of a data point

Actual distance in real world millimeters = distance measurement \* Distance Unit

- Distance measurement: Distance field of Channel 5 in Block 2
- Distance Unit: 4 mm

■ Draw the data point in a polar or rectangular coordinate system

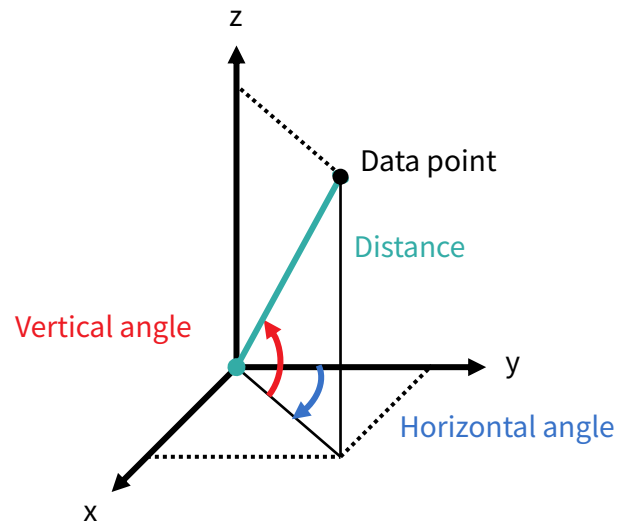

■ Obtain the real-time point cloud data by analyzing and drawing every data point in each frame

## 3.2 GPS Data Packet

GPS Data Packets are triggered every second.

### **Before NMEA messages are available from the external GPS module**

Each rising edge of the lidar's internal 1 Hz signal triggers a GPS Data Packet.

The time and date in the GPS Data Packets are unreal, starting from the UTC time 20 05 20 00 00 00 (year, month, day, hour, minute, second) and increasing with the internal 1 Hz signal.

### **Once the lidar receives the PPS (pulse-per-second) signal and NMEA messages**

The internal 1 Hz signal will be locked to the PPS. Each rising edge still triggers a GPS Data Packet.

Meanwhile, the lidar will extract the actual date and time from NMEA messages (\$GPRMC or \$GPGGA), and stamp them into both Point Cloud Data Packets and GPS Data Packets.

- Point Cloud Data Packets: 6-byte Date & Time (year, month, day, hour, minute, second)
- GPS Data Packets: 6-byte Date (year, month, day) and 6-byte Time (second, minute, hour)

The GPS module sends first the PPS signal and then the NMEA message. At the rising edge of the PPS pulse, the corresponding NMEA message is not yet available. Therefore, the lidar extracts date and time from the previous NMEA message and automatically adds 1 full second.

### **When GPS signal is lost**

The lidar will still trigger GPS Data Packets by the rising edge of the internal 1 Hz signal. However, the GPS time in the packets will be counted by the internal 1 Hz signal and will drift from the actual GPS time.

### 3.2.1 Ethernet Header

The source IP is 192.168.1.201 by default. The destination IP address is 255.255.255.255 and in broadcast form.

GPS Ethernet Header: 42 bytes		
Field	Bytes	Description
Ethernet II MAC	12	Destination: broadcast (0xFF: 0xFF: 0xFF: 0xFF: 0xFF: 0xFF) Source: (xx:xx:xx:xx:xx:xx)
Ethernet Data Packet Type	2	0x08, 0x00
Internet Protocol	20	Shown in the figure below
UDP Port Number	4	UDP source port (0x2710, represents 10000) Destination port (0x277E, represents 10110)
UDP Length	2	0x208, representing 520 bytes (8 bytes more than the size of the GPS UDP Data, shown in Figure 3.1)
UDP Checksum	2	-

```

⊞ Internet Protocol, Src: 192.168.1.201 (192.168.1.201), Dst: 255.255.255.255 (255.255.255.255)
  Version: 4
  Header length: 20 bytes
  ⊞ Differentiated Services Field: 0x00 (DSCP 0x00: Default; ECN: 0x00)
    Total Length: 540
    Identification: 0x1841 (6209)
  ⊞ Flags: 0x02 (Don't Fragment)
    Fragment offset: 0
    Time to live: 64
    Protocol: UDP (17)
  ⊞ Header checksum: 0x5e1f [correct]
    Source: 192.168.1.201 (192.168.1.201)
    Destination: 255.255.255.255 (255.255.255.255)
  
```

Figure 3.3 GPS Ethernet Header - Internet Protocol

### 3.2.2 UDP Data

GPS UDP data: 512 bytes						
Field	Bytes	Description				
GPS Time Data	18	Header	2 bytes	0xFFEE, 0xFF first		
		Date	6 bytes	Year, month, and day (2 bytes each, lower byte first) in ASCII		
		Time	6 bytes	Second, minute, and hour (2 bytes each, lower byte first) in ASCII		
		Reserved	4 bytes	-		
GPRMC/GPGGA Data	100	NMEA sentence that contains date and time ASCII code, valid till 2 bytes after the asterisk (*) The lidar can receive either GPRMC or GPGGA, see Chapter 4 (Web Control - Settings)				
Reserved	388	388 bytes of 0xDF				
GPS Positioning Status	1	ASCII code, obtained from \$GPRMC or \$GPGGA  <table style="width: 100%; border: none;"> <tr> <td style="width: 50%; vertical-align: top;">                             When \$GPRMC is selected:                              A (hex = 41) for Valid Position                              V (hex = 56) for Invalid Position                              NUL (hex = 0) for GPS being unlocked                         </td> <td style="width: 50%; vertical-align: top;">                             When \$GPGGA is selected:                              0 = invalid                              1 = GPS fix (SPS)                              2 = DGPS fix                              3 = PPS fix                              6 = estimated (dead reckoning)                         </td> </tr> </table>			When \$GPRMC is selected: A (hex = 41) for Valid Position V (hex = 56) for Invalid Position NUL (hex = 0) for GPS being unlocked	When \$GPGGA is selected: 0 = invalid 1 = GPS fix (SPS) 2 = DGPS fix 3 = PPS fix 6 = estimated (dead reckoning)
When \$GPRMC is selected: A (hex = 41) for Valid Position V (hex = 56) for Invalid Position NUL (hex = 0) for GPS being unlocked	When \$GPGGA is selected: 0 = invalid 1 = GPS fix (SPS) 2 = DGPS fix 3 = PPS fix 6 = estimated (dead reckoning)					
PPS Lock Flag	1	1 - locked      0 - unlocked				
Reserved	4	-				



■ GPRMC Data Format

\$GPRMC, <01>, <02>, <03>, <04>, <05>, <06>, <07>, <08>, <09>, <10>, <11>, <12>\*hh

Field #	Field	Description
<01>	UTC Time	Hour, minute, and second Typically in hhmmss (hour, minute, second) format
<02>	Location Status	A (hex = 41) for Valid Position V (hex = 56) for Invalid Position NUL (hex = 0) for GPS being unlocked
...		
<09>	UTC Date	Date information Typically in ddmmyy (day, month, year) format
...		

The lidar's GPS data interface is compatible with a variety of GPRMC formats, as long as:

<01> is the hour, minute, and second information

<09> is the date information.

For example, the following two formats are both acceptable:

\$GPRMC,072242,A,3027.3680,N,11423.6975,E,000.0,316.7,160617,004.1,W\*67

\$GPRMC,065829.00,A,3121.86377,N,12114.68322,E,0.027,,160617,,,A\*74

■ GPGGA Data Format

\$GPGGA, <01>, <02>, <03>, <04>, <05>, <06>, <07>, <08>, <09>, <10>, <11>, <12>\*hh

Field #	Field	Description
<01>	UTC Time	Hour, minute, and second Typically in hhmmss (hour, minute, second) format
...		
<06>	GPS Fix Quality	0 = invalid 1 = GPS fix (SPS) 2 = DGPS fix 3 = PPS fix 6 = estimated (dead reckoning)
...		

The lidar's GPS data interface is compatible with a variety of GPGGA formats, as long as:

<01> is the hour, minute, and second information

For example, the following two formats are both acceptable:

\$GPGGA,123519,4807.038,N,01131.000,E,1,08,0.9,545.4,M,46.9,M,,\*47

\$GPGGA,134658.00,5106.9792,N,11402.3003,W,2,09,1.0,1048.47,M,-6.27,M,08,AAAA\*60

### 3.2.3 GPS Data Analysis

```

> Data (512 bytes)
0000 04 d4 c4 eb 9b 37 ec 9f 0d 00 48 cb 08 00 45 00  ....7... ..H...E.
0010 02 1c c4 23 40 00 80 11 b0 66 c0 a8 01 c9 c0 a8  ...#@... -f.....
0020 01 2d 27 10 27 7e 02 08 00 00 ff ee 30 32 34 30  --'...'~... ....0240
0030 37 30 38 35 37 30 34 30 00 00 00 00 24 47 50 52  70857040 ....$GPR
0040 4d 43 00 2c 30 34 30 37 35 37 2e 37 36 2c 56 2c  MC.,0407 57.76,V,
0050 2c 2c 2c 2c 2c 2c 30 37 30 34 32 30 2c 2c 2c 4e  ,,,,,,07 0420,,,N
0060 2c 56 2a 30 36 36 36 36 36 36 36 36 36 36 36 36  ,V*06666 66666666

```

Figure 3.3 GPS Data Packet - UDP Data (Example)

**Date**

Field	Data (ASCII Code)	Characters	Meaning
Year	0x30 0x32	'0', '2'	20
Month	0x34 0x30	'4', '0'	04
Day	0x37 0x30	'7', '0'	07

**Time**

Field	Data (ASCII Code)	Characters	Meaning
Second	0x38 0x35	'8', '5'	58
Minute	0x37 0x30	'7', '0'	07
Hour	0x34 0x30	'4', '0'	04

**µs Time**

4 bytes, in units of µs, using the same clock source as the GPS Timestamp in Point Cloud Data Packets  
 Reset to 0 at the rising edge of each PPS signal

## 4 Web Control

Web control is used for setting parameters, checking device info, and upgrading.

To access web control

- 1) Connect the lidar to your PC using an Ethernet cable
- 2) Set the IP address according to Section 2.4 (Get Ready to Use)
- 3) Enter this URL into your web browser: 192.168.1.201

 Google Chrome and Mozilla Firefox are recommended.

## 4.1 Home

<b>Status</b>	
Spin Rate	600 rpm
GPS	Unlock
NMEA (GPRMC/GPGGA)	Unlock
PTP	Free Run

<b>Device Info</b>	<b>Device Log</b>
Model	PandarXT-16
S/N	XXXXXXXXXXXXXXXXXX
MAC Address	XX:XX:XX:XX:XX:XX
Software Version	1.0.10
Sensor Firmware Version	1.5.7
Controller Firmware Version	1.2.7

Button	Description
Device Log	Click to download a .JSON file that contains the lidar status, device info, all configurable parameters, and the upgrade log.

Parameter	Description								
Spin Rate	Spin Rate of the motor (rpm) = frame rate (Hz) * 60								
GPS	GPS (PPS) status <table border="1" data-bbox="521 347 1471 443"> <tr> <td>Lock</td> <td>Lidar's internal clock is in sync with GPS PPS</td> </tr> <tr> <td>Unlock</td> <td>Not in sync</td> </tr> </table>	Lock	Lidar's internal clock is in sync with GPS PPS	Unlock	Not in sync				
Lock	Lidar's internal clock is in sync with GPS PPS								
Unlock	Not in sync								
NMEA (GPRMC/GPGGA)	NMEA status <table border="1" data-bbox="521 544 1471 639"> <tr> <td>Lock</td> <td>After receiving a valid NMEA message</td> </tr> <tr> <td>Unlock</td> <td>Not receiving a valid NMEA message for over 2 s</td> </tr> </table>	Lock	After receiving a valid NMEA message	Unlock	Not receiving a valid NMEA message for over 2 s				
Lock	After receiving a valid NMEA message								
Unlock	Not receiving a valid NMEA message for over 2 s								
PTP	PTP status <table border="1" data-bbox="521 740 1883 979"> <tr> <td>Free Run</td> <td>No PTP master is selected.</td> </tr> <tr> <td>Tracking</td> <td>Attempting to sync with the selected PTP Master, but the absolute offset exceeds the user-specified limit in Section 4.2 (Settings).</td> </tr> <tr> <td>Locked</td> <td>Absolute offset is within the user-specified limit.</td> </tr> <tr> <td>Frozen (Holdover)</td> <td>Attempting to recover the connection to the PTP master.</td> </tr> </table>	Free Run	No PTP master is selected.	Tracking	Attempting to sync with the selected PTP Master, but the absolute offset exceeds the user-specified limit in Section 4.2 (Settings).	Locked	Absolute offset is within the user-specified limit.	Frozen (Holdover)	Attempting to recover the connection to the PTP master.
Free Run	No PTP master is selected.								
Tracking	Attempting to sync with the selected PTP Master, but the absolute offset exceeds the user-specified limit in Section 4.2 (Settings).								
Locked	Absolute offset is within the user-specified limit.								
Frozen (Holdover)	Attempting to recover the connection to the PTP master.								

## 4.2 Settings

[Reset All Settings](#)

---

**Control IP**

---

IPv4 Address	192.168.1.201
IPv4 Mask	255.255.255.0
IPv4 Gateway	192.168.1.1
VLAN	<input type="checkbox"/> 0

**Settings**

---

Destination IP	255.255.255.255
Lidar Destination Port	2368
Spin Rate	600 rpm
Return Mode	Last and Strongest
Sync Angle	<input type="checkbox"/> 0
Trigger Method	Angle Based
Clock Source	GPS
GPS Mode	GPRMC
GPS Destination Port	10110

(Continued on the next page)

(Continued)

Interstitial Points Filtering	OFF
Reflectivity Mapping	Linear Mapping
Standby Mode	In Operation / Standby

[Save](#)

Button	Description
Reset All Settings	Reset all the configurable parameters to factory defaults, including: <ul style="list-style-type: none"><li>• Section 4.2 (Settings)</li><li>• Section 4.3 (Azimuth FOV)</li></ul>
Save	Save and execute all the settings on this page. <ul style="list-style-type: none"><li>• Exception: Standby Mode takes effect immediately without having to click "Save".</li></ul>



## 4.2.1 Network Settings

Parameter	Options	Description								
VLAN	Default: OFF VLAN ID: 1 ~ 4094	To enable VLAN tagging: <ul style="list-style-type: none"> <li>• Make sure the receiving host also supports VLAN.</li> <li>• Check the checkbox and input the lidar's VLAN ID (same as the receiving host's VLAN ID).</li> </ul> <p><b>⚠ Warnings</b></p> <p>If the lidar's VLAN ID differs from the receiving host's, users will lose access to web control. To minimize such risks, the VLAN ID is zero (invalid value) by default.</p> <ul style="list-style-type: none"> <li>• When checking the checkbox, users will be alerted to input a valid VLAN ID.</li> <li>• When unchecking the checkbox, the VLAN ID will default to zero.</li> </ul> <p><b>💡 Notes</b></p> <ul style="list-style-type: none"> <li>• Once configured, the VLAN ID does not change during firmware upgrades.</li> <li>• When VLAN is enabled, PTP connection will be lost; when VLAN is disabled, PTP connection will automatically recover.</li> </ul>								
Destination IP	Any address except for 0.0.0.0, 127.0.0.1, and the lidar's IP.  Default: 255.255.255.255	<table border="1"> <thead> <tr> <th>Mode</th> <th>Destination IP</th> </tr> </thead> <tbody> <tr> <td>Broadcast (default)</td> <td>255.255.255.255</td> </tr> <tr> <td>Multicast</td> <td>User-defined</td> </tr> <tr> <td>Unicast</td> <td>Same as the PC's IP address</td> </tr> </tbody> </table>	Mode	Destination IP	Broadcast (default)	255.255.255.255	Multicast	User-defined	Unicast	Same as the PC's IP address
Mode	Destination IP									
Broadcast (default)	255.255.255.255									
Multicast	User-defined									
Unicast	Same as the PC's IP address									

## 4.2.2 Function Settings

Parameter	Options	Description
Spin Rate	600 RPM (default) 1200 RPM	The set spin rate is also shown on web control (see Section 4.1 Web Control – Home).
Return Mode	Single Return <ul style="list-style-type: none"> <li>• Last / Strongest / First</li> </ul> Dual Return <ul style="list-style-type: none"> <li>• Last and Strongest (default)</li> <li>• Last and First</li> <li>• First and Strongest</li> </ul>	Also shown in Point Cloud Data Packets (see the Return Mode field in Section 3.1.2 Point Cloud UDP Data).
Sync Angle	0° to 360°	<p>Phase lock angle</p> <ul style="list-style-type: none"> <li>• To activate this function, check the checkbox and input an azimuth.</li> <li>• At every full second, the lidar will rotate to that azimuthal position (see Section 1.2 Lidar Structure).</li> </ul> <p>Definition of full second</p> <ul style="list-style-type: none"> <li>• When GPS is locked: the rising edge of the GPS PPS signal</li> <li>• When PTP is tracking or locked: retrieved from the PTP master clock</li> <li>• When neither GPS nor PTP is locked: the rising edge of the lidar's internal 1 Hz signal</li> <li>• Detailed in Appendix II (Absolute Time of Point Cloud Data)</li> </ul> <p>To phase-lock multiple lidars: Connect the lidars to the same clock source and set the same sync angle, and these lidars will rotate to that same azimuthal position at every full second.</p>

Parameter	Options	Description				
Trigger Method	Angle-Based (default) Time-Based	<p>The way laser firings are triggered.</p> <table border="1"> <tr> <td>Angle-based</td> <td>Lasers fire every 0.09° at 5 Hz, 0.18° at 10 Hz, or 0.36° at 20 Hz..</td> </tr> <tr> <td>Time-based</td> <td>Lasers fire every 50 μs</td> </tr> </table>	Angle-based	Lasers fire every 0.09° at 5 Hz, 0.18° at 10 Hz, or 0.36° at 20 Hz..	Time-based	Lasers fire every 50 μs
Angle-based	Lasers fire every 0.09° at 5 Hz, 0.18° at 10 Hz, or 0.36° at 20 Hz..					
Time-based	Lasers fire every 50 μs					
Interstitial Points Filtering	OFF (default) ON	<p>To mitigate the interstitial points.</p> <p>Definition of interstitial points: when a beam partially hits on a front target's edge and further hits on a rear target, the return signal can result in a false point located between both targets.</p>				
Reflectivity Mapping	Linear (default) Nonlinear Mapping	<table border="1"> <tr> <td>Linear</td> <td>The Reflectivity field in Point Cloud Data Packets linearly represents target reflectivity (0 to 255%).</td> </tr> <tr> <td>Nonlinear</td> <td>Increases the contrast in low-reflectivity regions (see Appendix IV Nonlinear Reflectivity Mapping).</td> </tr> </table>	Linear	The Reflectivity field in Point Cloud Data Packets linearly represents target reflectivity (0 to 255%).	Nonlinear	Increases the contrast in low-reflectivity regions (see Appendix IV Nonlinear Reflectivity Mapping).
Linear	The Reflectivity field in Point Cloud Data Packets linearly represents target reflectivity (0 to 255%).					
Nonlinear	Increases the contrast in low-reflectivity regions (see Appendix IV Nonlinear Reflectivity Mapping).					
Standby Mode	In Operation (default) Standby	In Standby mode, the motor stops running and lasers stop firing.				

### 4.2.3 Time Settings

Clock Source	<b>GPS</b>
GPS Mode	GPRMC
GPS Destination Port	10110

Clock Source	<b>PTP</b>
Profile	1588v2
Time Offset for Lidar Lock	1
PTP Network Transport	UDP/IP
PTP Domain Number	0
PTP logAnnounceInterval	1
PTP logSyncInterval	1
PTP logMinDelayReqInterval	0

Parameter	Options	Description
Clock Source	GPS (default) PTP	External source of absolute time

■ With GPS Selected

Parameter	Options	Description									
GPS Mode	GPRMC (default) GPGGA	Format of the NMEA data received from the external GPS module (see Section 3.2.2 GPS UDP Data)									
Require PPS Lock	ON (default) OFF	<p>When this setting is ON, PPS must be locked (in addition to NMEA being locked) when updating the lidar's Date &amp; Time.</p> <ul style="list-style-type: none"> <li>The status of both NMEA and PPS signals are shown in Section 4.1 (Home).</li> <li>The complete logic is shown in the table.</li> </ul> <table border="1"> <thead> <tr> <th></th> <th>PPS locked</th> <th>PPS unlocked</th> </tr> </thead> <tbody> <tr> <td>NMEA locked</td> <td>Update Date &amp; Time using the current NMEA sentence.  Update the <math>\mu</math>s Timestamp using the current PPS signal.</td> <td>When "Require PPS Lock" is OFF, update Date &amp; Time using the current NMEA sentence. When "Require PPS Lock" is ON, do nothing.</td> </tr> <tr> <td>NMEA unlocked</td> <td>Update the <math>\mu</math>s Timestamp using the current PPS signal.</td> <td>Do nothing.</td> </tr> </tbody> </table> <p> Note</p> <ul style="list-style-type: none"> <li>Date &amp; Time: the lidar's system time, accurate to the second.</li> <li><math>\mu</math>s Timestamp: the <math>\mu</math>s part of the lidar's system time.</li> </ul>		PPS locked	PPS unlocked	NMEA locked	Update Date & Time using the current NMEA sentence.  Update the $\mu$ s Timestamp using the current PPS signal.	When "Require PPS Lock" is OFF, update Date & Time using the current NMEA sentence. When "Require PPS Lock" is ON, do nothing.	NMEA unlocked	Update the $\mu$ s Timestamp using the current PPS signal.	Do nothing.
	PPS locked	PPS unlocked									
NMEA locked	Update Date & Time using the current NMEA sentence.  Update the $\mu$ s Timestamp using the current PPS signal.	When "Require PPS Lock" is OFF, update Date & Time using the current NMEA sentence. When "Require PPS Lock" is ON, do nothing.									
NMEA unlocked	Update the $\mu$ s Timestamp using the current PPS signal.	Do nothing.									
Destination Port	Default: 10110	Port used for sending GPS Data packets									

■ With PTP Selected

The lidar does not output GPS Data Packets.

Parameter	Options	Description				
Profile	1588v2 (default) 802.1AS 802.1AS Automotive	IEEE timing and synchronization standard				
Time Offset for Lidar Lock	1 to 100 $\mu$ s (integer) Default: 1	Specify the upper limit of the absolute offset between Slave and Master when the lidar is in PTP Locked status; see Section 4.1 (Home)				
PTP Network Transport	UDP/IP (default) L2	Network transport protocol				
		<table border="1"> <tr> <td>UDP/IP</td> <td>Available only for 1588v2 profile</td> </tr> <tr> <td>L2</td> <td>Available for all profiles</td> </tr> </table>	UDP/IP	Available only for 1588v2 profile	L2	Available for all profiles
		UDP/IP	Available only for 1588v2 profile			
L2	Available for all profiles					
Domain Number	0 to 127 (integer) Default: 0	Domain attribute of the local clock				

When using the 1588v2 profile:

Parameter	Options	Description
PTP logAnnounceInterval	-2 to 3 Default: 1	Time interval between Announce messages Default: 1 log second (2 seconds)
PTP logSyncInterval	-7 to 3 Default: 1	Time interval between Sync messages Default: 1 log second (2 seconds)
PTP logMinDelayReqInterval	-7 to 3 Default: 0	Minimum permitted mean time between Delay_Req messages Default: 0 log second (1 second)

### 4.3 Azimuth FOV

Azimuth FOV Setting
For all channels ▾

Button	Description
Save	Save and execute all the settings on this page.

Parameter	Options	Description
Azimuth FOV Setting	For all channels (default)	Configuration mode of the azimuth FOV. The lidar outputs valid data only within the specified azimuth FOV ranges.
	Multi-section FOV	

 **Note**

- The angles in degrees are accurate to the first decimal place.
- If the Start Angle is larger than the End Angle, then the actual range is the union of [Start Angle, 360°) and [0°, End Angle).
  - For instance, when the angle range is set to be [270°, 90°), the actual azimuth FOV is [270°, 360°) ∪ [0°, 90°).

### 4.3.1 For all channels

Input a Start Angle and an End Angle to form a continuous angle range.  
This range applies to all channels.

Azimuth FOV Setting	<input type="text" value="For all channels"/>
Azimuth FOV for All Channels	Start: <input type="text" value="0.0"/>
	End: <input type="text" value="360.0"/>
<input type="button" value="Save"/>	



### 4.3.2 Multi-section FOV

Input multiple ( $\leq 5$ ) sets of Start Angles and End Angles to form multiple continuous angle ranges. These ranges apply to all channels.

Azimuth FOV Setting

Multi-section FOV ▾

---

Multi-section FOV	Start Angle	End Angle
Azimuth FOV 1	0.0	0.0
Azimuth FOV 2	0.0	0.0
Azimuth FOV 3	0.0	0.0
Azimuth FOV 4	0.0	0.0
Azimuth FOV 5	0.0	0.0

Save

## 4.4 Operation Statistics

These operating parameters are shown in real time:

Start-Up Counts	510
Internal Temperature	32.10°C
Total Operation Time	559 h 43 min
<hr/>	
<b>Internal Temperature</b>	<b>Operation Time</b>
<hr/>	
< -40 °C	0 h 1 min
-40 to -20 °C	0 h 46 min
...	...
100 to 120 °C	1 h 44 min
>120 °C	0 h 0 min

## 4.5 Upgrade

### Preparation

- Please contact Hesai technical support to receive encrypted and signed upgrade files.
- During the upgrade, it is recommended to place a protective cover (supplied with the lidar) or other opaque material over the lidar's cover lens.

### Upgrade

- Click the "Upload" button, select an upgrade file, and confirm your choice in the pop-up window.
- When the upgrade is complete, the lidar will automatically reboot, and the past versions will be logged in the Upgrade Log.

Button	Description
Restart	Software reboot Afterwards, the Start-Up Counts in the Operation Statistics page increments by 1.

Parameter	Current Value
Software Version	1.0.10
Firmware of Sensor Version	1.5.7
Firmware of Controller Version	1.2.7
Upgrade Log	-

 The above version numbers may be different from the actual. Please refer to the web page of the lidar used.

## 5 Communication Protocol

To acquire Hesai lidar's PTC (Pandar TCP Commands) and HTTP API Reference Manual, please contact Hesai technical support.

# 6 Sensor Maintenance

## ■ Cleaning

Stains on the product's cover lens, such as dirt, fingerprints, and oil, can negatively affect point cloud data quality. Please perform the following steps to remove the stains.

## ⚠ Warnings

- Turn OFF the power source before cleaning.
- To avoid damaging the optical coating, do NOT apply pressure when wiping the cover lens.

## 💡 Notes

- Only clean the stained area of the cover lens.
- Check before using a lint-free wipe. If the wipe is stained, use another.

- 1) Thoroughly wash your hands or wear a pair of powder-free PVC gloves.
- 2) To remove dust, blow dry air onto the cover lens, or use a piece of lint-free wipe to lightly brush across the dusty area.

To remove persistent stains, move on to the next step.

- 3) Spray the cover lens with warm, neutral solvent using a spray bottle.

Solvent type	Soft sponge with a mild soap solution 💡 Mild soap solution: maximum two tablespoons of neutral soap in 1 quart (1 liter) of water.
Solvent temperature	20 to 25°C

(Continued on the next page)

(Continued)

- 4) When the stains have loosened, dip a piece of lint-free wipe into the solvent made in Step 3, and gently wipe the cover lens back and forth along its surface.
- 5) Should another cleaning agent be applied to remove certain stains, repeat Steps 3 and 4.
- 6) Spray the cover lens with clean water, and gently wipe off the remaining liquid with another piece of lint-free wipe.

# 7 Troubleshooting

In case the following procedures cannot solve the problem, please contact Hesai technical support.

Symptoms	Points to Check
Indicator light is off on the connection box	<p>Verify that:</p> <ul style="list-style-type: none"><li>• power adapter is properly connected and in good condition;</li><li>• connection box is intact;</li><li>• input voltage and current satisfy the requirements in Section 2.3 (Connection Box).</li></ul> <p>Power on again to check if the symptom persists.</p>
Motor is not running	<p>Verify that:</p> <ul style="list-style-type: none"><li>• power adapter is properly connected and in good condition;</li><li>• if a connection box is used, the connection box is intact;</li><li>• input voltage and current satisfy the requirements in Section 1.4 (Specifications) and 2.3 (Connection Box);</li><li>• web control can be accessed (see "cannot open web control" on the next page);</li><li>• the lidar is not in standby mode (see Section 4.2 Web Control – Settings).</li></ul> <p>Power on again to check if the symptom persists.</p>

Symptoms	Points to Check
<p>Motor is running but no output data is received, neither on Wireshark nor on PandarView</p>	<p>Verify that:</p> <ul style="list-style-type: none"> <li>• Ethernet cable is properly connected (by unplugging and plugging again);</li> <li>• Lidar's Destination IP is correctly set on the Settings page of web control;</li> <li>• horizontal FOV is properly set on the Azimuth FOV page of web control;</li> <li>• firmware version of the sensor is correctly shown on the Upgrade page of web control;</li> <li>• Lidar is emitting laser light. This can be checked by using an infrared camera, an infrared sensor card, or a phone camera without infrared filter.</li> </ul> <p>Power on again to check if the symptom persists.</p>
<p>Can receive data on Wireshark but not on PandarView</p>	<p>Verify that:</p> <ul style="list-style-type: none"> <li>• Lidar Destination Port is correctly set on the Settings page of web control;</li> <li>• PC's firewall is disabled, or that PandarView 2 is added to the firewall exceptions;</li> <li>• PC's VLAN ID is the same as the lidar's; (<b>NOTE</b> This requirement applies only when the product model supports VLAN and that VLAN tagging is enabled.)</li> <li>• the latest version of PandarView 2 is installed on the PC.</li> </ul> <p>Power on again to check if the symptom persists.</p>



Symptoms	Points to Check
Cannot open web control	<p>Verify that:</p> <ul style="list-style-type: none"> <li>• Ethernet cable is properly connected (by unplugging and plugging again);</li> <li>• Lidar's IP is in the same subnet with the PC's. Users may use WireShark to check the lidar's IP that broadcasts data packets;</li> <li>• PC's VLAN ID is the same as the lidar's. (<b>NOTE</b> This requirement applies only when the product model supports VLAN and that VLAN tagging is enabled.)</li> </ul> <p>Afterwards:</p> <ul style="list-style-type: none"> <li>• restart PC, or connect the lidar to another PC;</li> <li>• power on again to check if the symptom persists.</li> </ul>
Abnormal packet size (missing packets)	<p>Verify that:</p> <ul style="list-style-type: none"> <li>• horizontal FOV is properly set on the Azimuth FOV page of web control;</li> <li>• motor's spin rate is steady on the Home page of web control;</li> <li>• Lidar's internal temperature is between -20°C and 95°C on the Operation Statistics page of web control</li> <li>• Ethernet is not overloaded;</li> <li>• no switch is connected into the network. The data transmitted from other devices may cause network congestion and packet loss.</li> </ul> <p>Afterwards:</p> <ul style="list-style-type: none"> <li>• connect the PC only to the lidar and check for packet loss;</li> <li>• power on again to check if the symptom persists.</li> </ul>

Symptoms	Points to Check
<p>Abnormal point cloud (obviously misaligned points, flashing points, or incomplete FOV)</p>	<p>Verify that:</p> <ul style="list-style-type: none"> <li>• Lidar's cover lens is clean. If not, refer to Section 6 (Sensor Maintenance) for the cleaning method;</li> <li>• Lidar's calibration file is imported; see <i>PandarView 2 User Manual (Use)</i>;</li> <li>• horizontal FOV is properly set on the Azimuth FOV page of web control;</li> <li>• motor's spin rate is steady on the Home page of web control;</li> <li>• Lidar's internal temperature is between -20°C and 95°C on the Operation Statistics page of web control.</li> </ul> <p>Afterwards, check for packet loss:</p> <ul style="list-style-type: none"> <li>• If no packet is missing and yet the point cloud flashes, please update PandarView 2 to the latest version (see the Download page of Hesai's official website or contact Hesai technical support) and restart the PC.</li> </ul> <p>If the point cloud is still abnormal:</p> <ul style="list-style-type: none"> <li>• try connecting the lidar to another PC;</li> <li>• power on again to check if the symptom persists.</li> </ul>
<p>GPS cannot be locked</p>	<p>Verify that:</p> <ul style="list-style-type: none"> <li>• GPS receiver is properly connected;</li> <li>• PPS signal is connected to the lidar;</li> <li>• Destination GPS Port is correct on the Settings page of web control;</li> <li>• input GPS signals satisfy the electrical requirements in Section 2.2 (Interface) and Section 2.3.1 (Connection Box).</li> </ul> <p>Power on again to check if the symptom persists;</p>

## Appendix I Channel Distribution Data

The Vertical Angles (Elevation) in the table below are design values.

The accurate values are in this lidar's unit's calibration file, see Section 1.3 (Channel Distribution) and Section 3.1.3 (Point Cloud Data Analysis).

Channel # in UDP Data	Horizontal Angle Offset (Azimuth)	Vertical Angle (Elevation)	Instrument Range (in meters)	Range (in meters) with Reflectivity
01 (Top)	0°	15°	120	50@10%
02	0°	13°	120	50@10%
03	0°	11°	120	50@10%
04	0°	9°	120	50@10%
05	0°	7°	120	80@10%
06	0°	5°	120	80@10%
07	0°	3°	120	80@10%
08	0°	1°	120	80@10%
09	0°	-1°	120	80@10%
10	0°	-3°	120	80@10%
11	0°	-5°	120	80@10%
12	0°	-7°	120	80@10%
13	0°	-9°	120	50@10%
14	0°	-11°	120	50@10%
15	0°	-13°	120	50@10%
16 (Bottom)	0°	-15°	120	50@10%

## Appendix II Absolute Time of Point Cloud Data

### ■ Source of Absolute Time

The lidar retrieves the current absolute time by connecting to an external clock source (GPS/PTP). Users can select the clock source, see Section 4.2 (Web Control - Settings).

## 1) GPS as the Clock Source

- The lidar connects to a third-party GPS module to obtain the PPS (pulse-per-second) signal and the NMEA sentence (\$GPRMC or \$GPGGA).
- Users may select either \$GPRMC or \$GPGGA sentences (see Section 4.2 Web Control – Settings).
- Users may check the signal status of GPS PPS and NMEA (see Section 4.1 Web Control - Home).
- The timing requirements of PPS and NMEA are shown in Section 2.2.1 (Pin Description).
- Each rising edge of the lidar's internal 1 Hz signal triggers a GPS Data Packet. The data format is detailed in Section 3.2 (GPS Data Packet).

The absolute time is updated as follows.

NMEA status	Date & Time (accurate to the second)	Lidar behavior
Unlocked	Virtual	Starts counting from a virtual UTC time (such as 2000-01-01 00:00:00) using the lidar's internal 1 Hz signal.
Locked	Synchronized	<p>At each rising edge of the internal 1 Hz signal, obtain the actual date and time by</p> <ul style="list-style-type: none"> <li>• extracting the date and time from the previous NMEA message, and</li> <li>• automatically adding 1 full second.</li> </ul> <p> If the "Require PPS Lock" switch is ON (see Section 4.2 Web Control – Settings): Only when both NMEA and PPS signals are locked will the Date &amp; Time (accurate to the second) be synchronized; otherwise, GPS signal status is deemed not good enough, and the Date &amp; Time will remain unsynchronized.</p>
Lost	Drifting	Starts counting from the last synchronized time, using the lidar's internal 1 Hz signal. Will gradually drift from the actual GPS time.

PPS status	μs time	Description
------------	---------	-------------

Unlocked	Not synchronized	The lidar's internal 1 Hz signal is not aligned with the GPS second.
Locked	Synchronized	The rising edge of the lidar's internal 1 Hz signal is aligned with the rising edge of the PPS signal (i.e. the start of each GPS second).
Lost	Drifting	Counts using the internal 1 Hz signal. Will gradually drift from the actual GPS second.

## 2) PTP as the Clock Source

- The lidar connects to a third-party PTP master to obtain the absolute time.
- Users may configure the PTP settings (see Section 4.2 Web Control – Settings).
- Users may check the PTP signal status (see Section 4.1 Web Control - Home).
- The lidar does not output GPS Data Packets.

The absolute time is updated as follows.

PTP Status	Date & Time (accurate to $\mu$ s)	Description
Free Run	Virtual	Starts counting from a virtual UTC time (such as 2000-01-01 00:00:00), using the lidar's internal 1 Hz signal.
Tracking or Locked	Synchronized	Extract the actual date and time from the PTP Master's messages.
Frozen	Drifting	Starts counting from the last synchronized time, using the lidar's internal 1 Hz signal. Will gradually drift from the actual PTP time.



### Notes

- PTP is a Plug & Play protocol; the lidar works as a PTP slave device and requires no additional setup.
- The timestamps and Date & Time fields in Point Cloud Data Packets strictly follow the PTP master device. Certain PTP master devices may have a specified offset from the lidar's time output. Please verify the configuration and calibration of your PTP master device.

### ■ Absolute Time of Point Cloud Data Packets

The absolute time of a Point Cloud Data Packet (denoted as  $t_0$ ) is calculated as follows:

$$t_0 = t_s + t_{ms}$$

where

- $t_s$  is the whole second part (see the Date & Time field).
- $t_{ms}$  is the microsecond part (see the Timestamp field).
- For definition of the above fields (see Section 3.1.2 Point Cloud UDP Data – Tail).

### ■ Start Time of Each Block

Given the absolute time of a Point Cloud Data Packet ( $t_0$ ), the start time of each block (i.e., the time when the first firing starts) can be calculated.

#### Single Return Mode

Block	Start Time ( $\mu$ s)
Block 8	$t_0 + 5.632$
Block N	$t_0 + 5.632 - 50 * (8 - N)$
Block 3	$t_0 + 5.632 - 50 * 5$
Block 2	$t_0 + 5.632 - 50 * 6$
Block 1	$t_0 + 5.632 - 50 * 7$

#### Dual Return Mode

Block	Start Time ( $\mu$ s)
Block 8 & Block 7	$t_0 + 5.632$
Block 6 & Block 5	$t_0 + 5.632 - 50 * 1$
Block 4 & Block 3	$t_0 + 5.632 - 50 * 2$
Block 2 & Block 1	$t_0 + 5.632 - 50 * 3$



### ■ Firing Time Offset of Each Channel

Assume that the start time of Block  $m$  is  $T(m)$ ,  $m \in \{1, 2, \dots, 8\}$ , then the laser firing time of Channel  $n$  in Block  $m$  is

$$t(m, n) = T(m) + \Delta t(n), n \in \{1, 2, \dots, 16\}.$$

In each round of firing, the firing sequence is from Channel 1 to Channel 16. The firing time offset in units of  $\mu\text{s}$ :

$$\Delta t(n) = 3.024 * (n-1) + 0.368$$

## Appendix III Power Supply Requirements

### ■ Input Voltage

To ensure that the input voltage at the lidar's Lemo connector is 9 to 36 V DC, please check the specifications of the power source and the voltage drop over cables.

We recommend using 26 AWG cables, which is the thickest wire gauge supported by the lidar

- Define the cable length from the power source to the lidar's Lemo connector as L (unit: m)
- When using 26 AWG cables, the estimated cable resistance is  $r = 0.3L$  (unit:  $\Omega$ )
- Define the source voltage as  $U_{in}$  (V). The cable voltage drop of the lidar operating at 10 Hz under room temperature ( $23 \pm 5^\circ\text{C}$ ) can be estimated:

$$U_{drop}(V) = \frac{U_{in} - \sqrt{U_{in}^2 - 40r}}{2}$$

Users may also estimate the cable voltage drop using the following lookup table.

When cable length exceeds 10 m, source voltage should be at least 24 V.

Estimation of Cable Voltage Drop

Cable Total Length L	Source Voltage $U_{in} = 12 V$	Source Voltage $U_{in} = 24 V$	Source Voltage $U_{in} = 36 V$
1.5 m	0.39 V	0.19 V	0.13 V
2 m	0.52 V	0.25 V	0.17 V
5 m	1.42 V	0.64 V	0.42 V
10 m	3.55 V (lidar's input voltage < 9 V)	1.32 V	0.85 V

💡 When the lidar's input voltage approaches 36 V, make sure there is no additional overshoot in the external power system. Even a short period of overvoltage can cause irreversible damage to the lidar.

### ■ Power Consumption

The lidar's peak power consumption is below 30 W in all operating conditions.

- After a power-on in an ambient temperature of 0°C or below, power consumption typically remains around 15 W for a period of time.
- When setting the frame rate to 20 Hz, power consumption will also be higher than the typical value in Section 1.4 (Specifications).

In the above or similar conditions, we recommend providing at least 30 W of input power to the lidar.

### ■ Power Up/Down

During a power-up, the voltage requirements are charted in Figure IV.1

- The lidar's input voltage should remain under 1 V for more than 50 ms before ramping up
- During the ramp-up, the input voltage should climb to 90% of its designed value in less than 500 ms

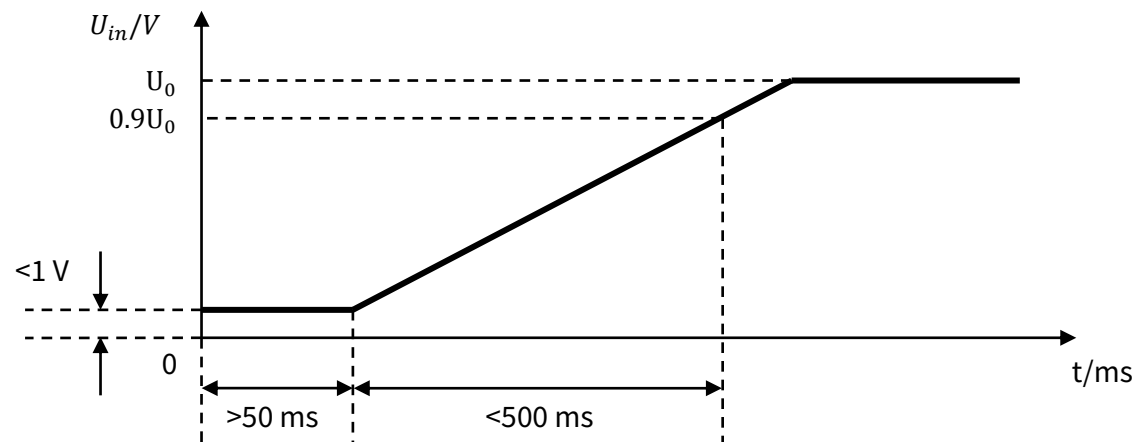

Figure IV.1 Voltage Requirements during a Power-Up

During a power-down, the lidar's input voltage, after dropping below 1 V, should remain for more than 50 ms before the next power-up.

## Appendix IV Nonlinear Reflectivity Mapping

By default, the 1-byte reflectivity data in Point Cloud Data Packets linearly represents target reflectivity from 0 to 255%.

Alternatively, users may choose the Nonlinear Mapping mode (see Section 4.2 Web Control - Settings).

The nonlinear relationship is detailed below.

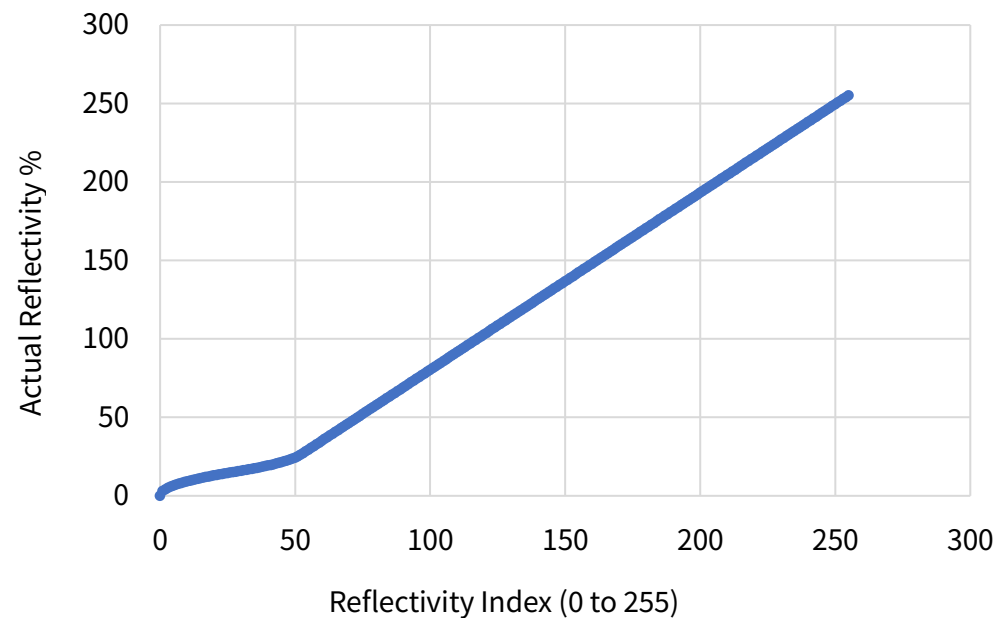

Nonlinear Reflectivity Mapping (Continued on the Next Page)

Reflectivity Index (0 to 255)	Reflectivity (%)	Reflectivity Index (0 to 255)	Reflectivity (%)	Reflectivity Index (0 to 255)	Reflectivity (%)	Reflectivity Index (0 to 255)	Reflectivity (%)
0	0	20	12.91	40	19.2	60	34.99
1	2.89	21	13.23	41	19.59	61	36.12
2	4.08	22	13.54	42	20	62	37.25
3	5	23	13.84	43	20.43	63	38.37
4	5.77	24	14.14	44	20.87	64	39.5
5	6.45	25	14.43	45	21.34	65	40.63
6	7.07	26	14.72	46	21.84	66	41.76
7	7.64	27	15	47	22.36	67	42.89
8	8.16	28	15.28	48	22.93	68	44.02
9	8.66	29	15.57	49	23.55	69	45.15
10	9.13	30	15.86	50	24.23	70	46.28
11	9.57	31	16.16	51	25	71	47.4
12	10	32	16.46	52	25.92	72	48.53
13	10.41	33	16.77	53	27.09	73	49.66
14	10.8	34	17.09	54	28.22	74	50.79
15	11.18	35	17.42	55	29.35	75	51.92
16	11.55	36	17.75	56	30.47	76	53.05
17	11.9	37	18.1	57	31.6	77	54.18
18	12.25	38	18.45	58	32.73	78	55.3
19	12.58	39	18.82	59	33.86	79	56.43

Nonlinear Reflectivity Mapping (Continued on the Next Page)

Reflectivity Index (0 to 255)	Reflectivity (%)	Reflectivity Index (0 to 255)	Reflectivity (%)	Reflectivity Index (0 to 255)	Reflectivity (%)	Reflectivity Index (0 to 255)	Reflectivity (%)
80	57.56	100	80.14	120	102.71	140	125.28
81	58.69	101	81.26	121	103.84	141	126.41
82	59.82	102	82.39	122	104.97	142	127.54
83	60.95	103	83.52	123	106.09	143	128.67
84	62.08	104	84.65	124	107.22	144	129.8
85	63.21	105	85.78	125	108.35	145	130.93
86	64.33	106	86.91	126	109.48	146	132.05
87	65.46	107	88.04	127	110.61	147	133.18
88	66.59	108	89.16	128	111.74	148	134.31
89	67.72	109	90.29	129	112.87	149	135.44
90	68.85	110	91.42	130	114	150	136.57
91	69.98	111	92.55	131	115.12	151	137.7
92	71.11	112	93.68	132	116.25	152	138.83
93	72.23	113	94.81	133	117.38	153	139.95
94	73.36	114	95.94	134	118.51	154	141.08
95	74.49	115	97.07	135	119.64	155	142.21
96	75.62	116	98.19	136	120.77	156	143.34
97	76.75	117	99.32	137	121.9	157	144.47
98	77.88	118	100.45	138	123.02	158	145.6
99	79.01	119	101.58	139	124.15	159	146.73

Nonlinear Reflectivity Mapping (Continued on the Next Page)

Reflectivity Index (0 to 255)	Reflectivity (%)	Reflectivity Index (0 to 255)	Reflectivity (%)	Reflectivity Index (0 to 255)	Reflectivity (%)	Reflectivity Index (0 to 255)	Reflectivity (%)
160	147.86	180	170.43	200	193	220	215.58
161	148.98	181	171.56	201	194.13	221	216.7
162	150.11	182	172.69	202	195.26	222	217.83
163	151.24	183	173.81	203	196.39	223	218.96
164	152.37	184	174.94	204	197.52	224	220.09
165	153.5	185	176.07	205	198.65	225	221.22
166	154.63	186	177.2	206	199.77	226	222.35
167	155.76	187	178.33	207	200.9	227	223.48
168	156.88	188	179.46	208	202.03	228	224.6
169	158.01	189	180.59	209	203.16	229	225.73
170	159.14	190	181.72	210	204.29	230	226.86
171	160.27	191	182.84	211	205.42	231	227.99
172	161.4	192	183.97	212	206.55	232	229.12
173	162.53	193	185.1	213	207.67	233	230.25
174	163.66	194	186.23	214	208.8	234	231.38
175	164.79	195	187.36	215	209.93	235	232.51
176	165.91	196	188.49	216	211.06	236	233.63
177	167.04	197	189.62	217	212.19	237	234.76
178	168.17	198	190.74	218	213.32	238	235.89
179	169.3	199	191.87	219	214.45	239	237.02

Nonlinear Reflectivity Mapping (Continued)

Reflectivity Index (0 to 255)	Reflectivity (%)
240	238.15
241	239.28
242	240.41
243	241.53
244	242.66
245	243.79
246	244.92
247	246.05
248	247.18
249	248.31
250	249.44
251	250.56
252	251.69
253	252.82
254	253.95
255	255.08



## Appendix V Legal Notice

Copyright (C) 2017-2023 Hesai Technology Co., Ltd.

All rights reserved. Use or reproduction of this manual in parts or its entirety without the authorization of Hesai is prohibited.

Hesai Technology makes no representations or warranties, either expressed or implied, with respect to the contents hereof and specifically disclaims any warranties, merchantability, or fitness for any particular purpose. Further, Hesai Technology reserves the right to revise this publication and to make changes from time to time in the contents hereof without obligation to notify any person of such revision or changes.

HESAI and HESAI logo are registered trademarks of Hesai Technology. All other trademarks, service marks, and company names in this manual or on Hesai's official website are properties of their respective owners.

The software included in this product contains copyright that is registered under Hesai Technology. Any third party is not permitted, except as expressly permitted by licensor or expressly required by applicable law, to decompile, reverse engineer, disassemble, modify, rent, lease, loan, distribute, sublicense, create derivative works based on the whole or any part of the software.

Hesai Product Warranty Service Manual is on the Warranty Policy page of Hesai's official website: <https://www.hesaitech.com/warranty-policy/>

## Hesai Technology Co., Ltd.

Phone: +86 400 805 1233

Website: [www.hesaitech.com](http://www.hesaitech.com)

Address: Building L2, Hongqiao World Centre, Shanghai, China

Business Email: [info@hesaitech.com](mailto:info@hesaitech.com)

Service Email: [service@hesaitech.com](mailto:service@hesaitech.com)



HESAI Wechat